



2021 PROVISIONAL TECHNICAL REGULATIONS

FIM Moto3™ Junior World Championship

For the purposes of simplicity and convenience/utility these Regulations also include the:

European Moto2™ Championship & Hawkerc European Talent Cup

Moto3™ ***JUNIOR***
WORLD CHAMPIONSHIP

Moto2™
EUROPEAN CHAMPIONSHIP

HAWKERS ***EUROPEAN***
Talent CUP

| YEAR 2021 | | |
|-----------|--------------------|--|
| Version | Applicable as from | Modified paragraphs |
| 0 | 01.01.2021 | <p><u>Moto3 Jr</u> 2.3.3.2 9); 2.3.3.5 2)</p> <p><u>Moto2 (Appendix 5)</u> 3.2.13; 3.3; 3.9.1.3; 3.9.2.1; 3.9.3; 3.12.2; 3.13; 3.17.1; 3.19; 3.20; 3.21</p> <p><u>600STK (Appendix 6)</u> 4.6.4; 4.6.6; 4.6.8.19; 4.6.10; 4.6.14.8; 4.6.15; 4.6.16</p> <p><u>ETC (Appendix 7)</u> 5.6.3; 5.6.5; 5.6.6; 5.6.7.19; 5.6.8.1 m); 5.6.9; 5.6.9.2 b) 2.; 5.6.9.4 e); 5.6.9.6 b); 5.6.13; 5.6.14; 5.6.15</p> <p><u>General Appendices 8 – 12 (new order)</u> Appendix 8: Motorcycle frame Appendix 9: Transponder Installation Appendix 10: Fuel Specification Appendix 11: Riders' equipment (& FIM Helmets standards) Appendix 12: Procedure for technical control</p> |
| 1 | | |
| 2 | | |
| 3 | | |
| 4 | | |
| 5 | | |

Articles amended as from the 1ST January 2021 are in **bold green**

2. TECHNICAL REGULATIONS

2.1 Introduction

2.1.1

The Championship is for motorcycles, i.e. vehicles with two wheels that make one track propelled only by an internal combustion engine, controlled by one rider.

2.1.2

Providing that the following Regulations are complied with, the constructors are free to be innovative with regard to design, materials and overall construction of the motorcycle.

2.1.3

In the Technical Regulations section, the term “Organiser” refers to the Championship Organiser and/or Promoter.

2.2 Classes

The following classes will be accommodated, which will be designated by engine type:

Moto3™ Junior
(ref. Section 2.3)

Up to 250cc. 4-stroke only, single cylinder only, maximum cylinder bore 81mm.

European Moto2™
(ref. Appendices 5 & 6)

Moto2™ Official Engine & Superstock 600 class also allowed.

European Talent Cup
(ref. Appendix 7)

HONDA NSF 250 (Type MR03) Official Motorcycle

2.3 Moto3™ Junior Technical Regulations

2.3.1 Definition

Up to 250cc. 4-stroke only, single cylinder only, maximum cylinder bore 81mm – prototypes.

2.3.2 Engines

2.3.2.1 Description

1. Engines may operate on the reciprocating piston four stroke principle only. The normal section of each engine cylinder and piston in plan view must be circular. Circular section cylinders & pistons are defined as having less than 5% difference in the diameter measured at any two points.
2. Engines must be normally aspirated.
3. Cubic capacity of the engine will be defined by the swept volume of the cylinder, ie. the area of the bore of the cylinder multiplied by the stroke, multiplied by the number of cylinders.
No tolerance on capacities is permitted.
Engine capacity will be measured at ambient temperature.
4. Maximum engine RPM in acceleration is controlled by the official ECU. The RPM Limiter strategy target is set at 13,500 rpm.
5. Maximum of 1 ignition driver.
6. Pneumatic and/or hydraulic valve systems are not permitted.
7. Valve timing system drive must be by one chain. An intermediate drive gear which rotates on only one axle or rotation centre is allowed in the system (refer to Appendix 1 for some examples of permitted systems).

2.3.2.2 Electronics

1. The only allowed Electronic Control Unit (ECU) is the Race version of Dellorto DoPE 2.0 and DoPE 3.0 ECU. The ECU must use FW 2017 or subsequent. This ECU will have a maximum of one ignition driver and include an engine RPM limiter, and the ECU must remain unmodified in hardware and software. The use of any additional device or module to modify the signals sent from the ECU to the actuators is forbidden. Injectors, bypass systems and ignition must be operated exclusively by the original and unmodified ECU signal.
2. Both “Team” and “Manufacturer” version of the ECU software supplied by the ECU manufacturer can be used by the team to modify the ECU configuration file. The only permitted changes by the team are the setting (tuning) options included in this software.
3. The only allowed dashboard is Dellorto DoDASH. The dashboard includes a GPS, to be used for data acquisition. The upper edge of the dashboard with GPS antenna must not be shielded.

4. Compulsory data acquisition channel list provided by Dellorto must be used. Data acquisition file in format .dop and .dopz. must be supplied to Organizer upon request for technical controls.
5. The datalogger download cable in the wiring harness must be of the approved standard type or one which is completely compatible with it. Details of connector type and connection are detailed in the online documents from the official ECU supplier.*
* for all ECU and electronic items identified with this symbol, details are available at the website: <http://www.dellorto-pe.com/>
6. Compulsory Engine Management features:
Refer to Appendix 2 for details of compulsory engine management equipment and design, including dashboard, ignition and sensors.
7. Recommended Engine Management features:
Refer to Appendix 3 for details of recommended engine management and electronic equipment and design, including timing pattern, O² sensor, knock sensor, idle control.
8. There is a compulsory official Initial Mapping and Set Up Procedure for new engines manufacturers to be compatible with the official ECU. Refer to Appendix 4 for initial ECU set-up procedure options.

2.3.2.3 Fuel system

1. Maximum relative fuel pressure is 5.0 Bar.
2. Variable-length inlet systems are not permitted.
3. Only one throttle control valve is permitted to control the power demand by the rider, which must be controlled exclusively by mechanical means (eg. cable) operated by the rider only. No other powered moving devices (except injectors and the idle control air bypass) are permitted in the inlet tract before the engine intake valve.
No interruption of the mechanical connection between the rider's input and the throttle is allowed.
4. Idle speed (including engine braking) adjustment by means of an air bypass system, controlled by the ECU is allowed. The maximum size of such air bypass is 12mm equivalent diameter; control systems may include a butterfly-type control valve.
5. Fuel injectors must be located upstream of the engine intake valves.
6. A maximum of 2 fuel injectors per throttle body, and 2 independent fuel injector drivers, controlled by the ECU, is permitted.
7. Other than engine sump breather gases, only air or air/fuel mixture is permitted in the inlet tract and combustion chamber.
8. Only fuel of the current year from the appointed fuel supplier is permitted. This fuel will be available at all official events, and will conform to the FIM Moto3™ Junior World Championship specification.
The use of this fuel without any addition or alteration is mandatory during all events (free practices, qualifying practices, warm-up and races).
9. The fuel on the motorcycle must not be below the prevailing ambient temperature, as measured by the Technical Director. Other than a simple removable fuel tank cover,

the use of any device on the motorcycle to artificially decrease the fuel temperature below ambient temperature is forbidden.

10. Any quality of oil may be used.

2.3.2.4 Exhaust

1. Only reciprocating inlet and exhaust valves are permitted, with a maximum of 2 valves each inlet and exhaust.
2. The outlet of the exhaust must not extend behind a line drawn vertically through the edge of the rear tyre.
3. For safety reasons the exposed edge of the exhaust pipe outlet must be rounded to avoid any sharp edges.
4. Variable length exhaust systems are not permitted.
5. Exhaust Gas Recirculation (EGR) systems are not permitted.
6. No moving parts (e.g. valves, baffles...) are allowed in the exhaust systems.
7. The noise limit will be a maximum of 115 dB/A, measured in a static test at 5.500rpm.

2.3.2.5 Control systems

1. The use of hydraulic and/or pneumatic pressurized powered systems is not allowed. All hydraulic systems on the motorcycle must be powered only by the rider's manual inputs with the following clarifications:
 - Normal hydraulic hand/foot controls such as master/slave cylinders for brakes/clutch are allowed.
 - Oil/water pumps for engine lubricating/cooling are allowed.
 - The use of engine lubricating oil for any purpose other than lubrication and cooling (such as powered hydraulic systems) is not allowed.
2. Variable valve timing and variable valve lift systems, driven by hydraulic and/or electric/electronic systems are not permitted. Decompression systems which operate only at engine start are permitted, but variable valve timing/valve lift systems which operate other than at engine start, are not permitted.

2.3.2.6 Transmission

1. A maximum of six (6) gears ratios is permitted.
2. Twin clutch transmission systems (DSG) are not permitted.
3. Continuously Variable Transmission systems (CVT) are not permitted.
4. Automatic transmission systems are not permitted. Only manually transmissions with gearshifts assisted by a quick-shifter systems are permitted.

5. A maximum of 2 possible gear ratios for each gearbox speed and 3 possible ratios for the primary drive gear is permitted. Teams will be required to declare the gearbox ratios chosen for each gear at the beginning of the season, and only these ratios may be used during the entire season.
6. Gearbox systems must be of the conventional type. That is constant-mesh with engagement dogs as an integral part of the gear, and/or shifters (eg. "dog rings"), actuated by shift forks and shift cam or drum, with only one set of gears engaging at one time. So-called "seamless shift" transmissions (also known as Automated Manual Transmission, Instantaneous Gearchange System, etc.) are not permitted.
7. Electro-mechanical or electro-hydraulic clutch actuating systems are not permitted.

2.3.2.7 Materials

NB. "X-based alloy" or "X materials" here means the element X (e.g. Fe, for ferrous or iron-based alloy) must be the most abundant element in the alloy, on a % w/w basis.

1. The use of titanium in the construction of the following parts is forbidden:
 - The frame/chassis, excluding bolts and fasteners (the decision of the Technical Director will be final when determining what constitutes a part of the chassis).
 - The swinging arm, excluding bolts and fasteners.
 - The swinging arm spindles
 - The wheel spindles (for wheel spindles, the use of light alloys is also forbidden).
 - The handlebars.
 - The front suspension inner and outer tubes and bottoms (ie. Axle mounting point).
 - The shock absorber piston shaft and damper tube.
2. The basic structure of the crankshaft and camshafts must be made from ferrous materials, steel or cast iron. Inserts of a different material are allowed in the crankshaft for the sole purpose of balancing.
3. Pistons, cylinder heads and cylinder blocks may not be composite structures which use carbon or aramid fibre reinforcing materials.
4. Brake calipers must be made from aluminium materials with a modulus of elasticity no greater than 80 GPa.
5. All connectors from the brake hose to the brake calipers (front and rear) and the brake master cylinders must have structural components (*) manufactured from either steel or titanium alloys with a tensile strength no less than 500 Mpa.
* Brass connectors are permitted for rear brake hoses only.
6. No parts of the motorcycle or engine may be made from metallic materials which have a specific modulus of elasticity greater than 50 GPa / (g/cm³).
7. The use of MMC (Metal Matrix Composite) and FRM (Fibre Reinforced Metal) materials is forbidden.
8. The following materials restrictions apply:
 - a) Engine crankcases, cylinder blocks and cylinder heads must be made from cast aluminium alloys.

- b) Pistons must be made from an aluminium alloy.
- c) Piston pins must be made from ferrous materials.
- d) Connecting rods, valves and valve springs must be made from either ferrous or titanium-based alloys.
- e) The use of carbon fibre for the main construction of the swing arm is forbidden.

2.3.3 Chassis

Chassis must be a prototype, the design and construction of which is free within the constraints of the FIM Moto3™ Junior Technical Regulations.

2.3.3.1 Weights

1. Minimum total weight of Motorcycle + Rider: 149 kg.
2. Ballast may be added to achieve the minimum weights.
3. Weight may be checked at the initial technical control, but the main control of weight will be made at the end of practice sessions or at the end of the race. The weight of the motorcycle will be that measured in the form that the motorcycle participated, with fuel tank on and including normal levels of oil and water, and all additional equipment attached to the motorcycle, for example timekeeping transponders, camera equipment, electronic datalogging equipment, etc.
The weight checked will be the total of the rider with full protective clothing plus the weight of the motorcycle. Random weight controls may be carried out during practice in a designated weighing area.

2.3.3.2 Safety and construction criteria

Note: please also refer to [Appendix 8](#).

1. Throttle Twist grips

The throttle twist-grip must close automatically when released.

2. Steering

- a) Handlebars must have a width of not less than 450 mm and their end must be solid or rubber covered. The width of the handlebar is defined as the width measured between the outside of the handlebar grips or throttle twist grips.
- b) There must be at least 15 degrees of movement of the steering each side of the centre line.
- c) Stop must be fitted to ensure a clearance of at least 30 mm between the handlebar and the fuel tank frame and/or bodywork when at the extremes of steering lock.

3. Footrests

Footrest must have rounded ends with a minimum solid spherical radius of 8 mm.

4. Handlebar levers

Handlebar levers must not be longer than 200 mm measured from the pivot point.

5. Clearances

- a) The motorcycle, unloaded, must be capable of being leaned at an angle of 50 degrees from the vertical without touching the ground, other than with the tyre.
- b) There must be a clearance of at least 15 mm around the circumference of the tyre at all positions of the motorcycle suspension and all positions of the rear wheel adjustment.

6. Breather pipes

Any breather pipe from the engine or gearbox must discharge into the airbox and/or a suitable container.

7. Chain Guards

A guard must be fitted in such a way as to prevent trapping between the lower drive chain run and the final drive sprocket at the rear wheel.

8. Engine Covers

Lateral engine covers containing oil and which could be in contact with the ground during a crash, should be protected by a second cover made from composite materials, e.g. nylon, carbon or Kevlar®. Plates and/or bars from aluminium or steel are also permitted. All these devices must be designed to be resistant against sudden shocks and abrasion and must be fixed properly and securely.

Such protection is mandatory as directed by the Technical Director.

9. Timing transponders

Note: please refer to Appendix 9

10. Safety lights

All motorcycles must have a functioning red light mounted at the rear of the machine, to be used in rain or low visibility conditions. The team must ensure that the light is switched on whenever a rain tyre is fitted on the motorcycle.

Lights must comply with the following:

- a) The lighting direction must be parallel to the center line of the motorcycle (running direction) and it must be clearly visible from the rear, at least 15 degrees to both the left and right sides of the center line of the motorcycle.
- b) It must be safely mounted on the very end of seat/rear bodywork and approximately on the center line of the motorcycle. In case of dispute over the mounting position or visibility of the Rear Safety Light, the decision of the Technical Director will be final.
- c) The power output/luminosity must be equivalent to approximately 10-15W (incandescent) or 0.6-1.8W (led).
- d) Able to be switched on and off by the rider when seated on the machine.
- e) Safety light power supply may be separated from the motorcycle main wiring and battery.

2.3.3.3 Brakes

1. Motorcycles must have a minimum of one brake on each wheel that is independently operated.

2. Only brake discs of ferrous materials are allowed.
3. The proportion of ceramic composite materials in brake discs must not exceed 2% by mass. Ceramic materials are defined as inorganic, non metallic solids (e.g. Al_2O_3 , SiC , B_4C , Ti_5Si_3 , SiO_2 , Si_3N_4).
Refer to Art. 2.3.2.7. 4) and 5) for other permitted materials in brake component construction.
4. Motorcycles must be equipped with brake lever protection, intended to protect the handlebar brake lever(s) from being accidentally activated in case of collision with another machine. Acceptable protection includes the fairing extending sufficiently to cover the brake lever, as viewed from the front.
Such devices must be strong enough to function effectively and designed so that there is no risk for the rider to be injured or trapped by it, and it must not be considered a dangerous fitting (at the sole discretion of the Technical Director).
In case the brake lever protection is attached to any part of the braking system (e.g. brake master cylinder), then the brake system manufacturer must officially confirm in writing to the Technical Director that the device does not interfere with the proper brake operation.
5. Anti-lock Brake Systems (ABS) are not permitted. Braking inputs must be powered and controlled solely by the rider's manual inputs. Conventional hydraulic hand/foot controls such as master/slave cylinders for brake systems are allowed (refer also to Art. 2.3.2.5 Control Systems) but no increase or control of brake pressure by electronic or mechanical systems apart from the rider's direct manual inputs are allowed. Specifically, brake systems designed to prevent the wheel from locking when the rider applies the brake are forbidden.

2.3.3.4 Suspensions and dampers

1. Electric/electronic controlled suspension, ride height and steering damper systems are not allowed. Adjustments to the suspension and steering damper systems may only be made by manual human inputs and mechanical/hydraulic adjusters.

2.3.3.5 Fuel tanks

1. Fuel caps must be leak proof and have a positive closing device.
2. Fuel tank breather pipes must include a non-return valve. Fuel tank breather pipes must discharge into a suitable container **or containers**, with a minimum capacity of 200cc.
3. Fuel tanks of all construction types must be filled with fire retardant material or be lined with a fuel cell bladder.
4. Except for the case that a fuel tank is fixed on the chassis with bolts, all fuel lines from the fuel tank to the engine/injector system should have a self sealing breakaway valve. This valve must separate at less than 50% of the load required to break any part of the fuel line or fitting or to pull it out of the fuel tank.
5. Refuelling may only be carried out from an unpressurised container, and the motorcycle fuel tank may not be artificially pressurised above atmospheric pressure

at any time. It is allowed to vent the fuel tank to the atmosphere via the airbox in order to equalise pressure in the airbox and fuel tank.

2.3.3.7 Bodywork

Note: please also refer to [Appendix 8](#).

1. The windscreen edge and the edges of all other exposed parts of the streamlining must be rounded.
2. The maximum width of bodywork must not exceed 600 mm. The width of the seat or anything to its rear shall not be more than 450 mm (exhaust pipes excepted).
3. Bodywork must not extend more than 150mm beyond a line drawn vertically from the center of the front wheel spindle and a line drawn vertically at the rearward edge of the rear tyre. The suspension should be fully extended when the measurement is taken.
4. When viewed from the side, it must be possible to see:
 - a) At least 180 degrees of the rear wheel rim.
 - b) The whole of the front rim, other than the part obscured by the mudguard, forks, brake parts or removable air-intake.
 - c) The rider, seated in a normal position with the exception of the forearms.

Notes: No transparent material may be used to circumvent the above rules. Covers for brake parts or wheels are not considered to be bodywork obstructing the view of wheel rims in regard to the above rules.

5. No part of the motorcycle may be behind a line drawn vertically at the edge of the rear tyre.
6. The seat unit shall have a maximum height of the (approximately) vertical section behind the rider's seating position of 150 mm. The measurement will be taken at a 90° angle to the upper surface of the flat base at the rider's seating position, excluding any seat pad or covering.
7. Mudguards are not compulsory. When fitted, front mudguards must not extend:
 - a) Front leading edge: In front of a line drawn upwards and forwards at 45 degrees from a horizontal line through the front wheel spindle.
 - b) Rear trailing edge: Below a line drawn horizontally and to the rear of the front wheel spindle.The mudguard mounts/brackets and fork-leg covers, close to the suspension leg and wheel spindle, and brake disc covers are not considered part of the mudguard.
8. Devices or shapes protruding from the fairing or bodywork and not integrated in the body streamlining (eg. wings, fins, bulges, etc.), that may provide an aerodynamic effect (eg. providing downforce, disrupting aerodynamic wake, etc.) are not allowed. The Technical Director will be the sole judge of whether a device or fairing design falls into the above definition.
Moving aerodynamic devices are prohibited.

9. The lower fairing has to be constructed to hold, in case of an engine breakdown, at least half of the total oil and engine coolant capacity used in the engine (minimum 2.5 liters). This measurement should be taken with the fairing fitted to the motorcycle, whilst both wheels are on the ground and the motorcycle is upright at 90° to the horizontal.
The lower fairing may incorporate a maximum of two holes of 25mm. These holes must remain closed in dry conditions and must be only opened in wet race conditions.

2.3.3.8 Wheel rims

1. The only permitted wheel rim sizes are:

Front 2.50" x 17"

Rear 3.50" x 17"

2. Composite construction wheels (including carbon fibre reinforced, glass fibre reinforced, and similar) are not permitted. The permitted materials for wheel construction are magnesium and aluminium alloys.

2.3.3.9 Tyre restrictions

1. Only tyres from the official tyre supplier may be used and each team must sign a contract.
The tyre specifications available at each event will be determined by the Championship Promoter. Only homologated tyres in each event are permitted.
The use of any device on the wheel to adjust the tyre pressure whilst on track is prohibited. The Technical Stewards and/or the official tyre supplier may perform random controls during the qualifying practices and races.
2. The maximum number of rear tyres allowed to use during the qualifying practice are THREE (3). Only the rear slick tyres need to be marked with a tyre sticker.
The wet tyres will not need to be marked with a tyre sticker and will not be considered in the total number of tyres available for use.
A maximum of ONE (1) rear slick tyre per race may be used. Only the race rear slick tyre shall be marked with a code differentiable qualifying tyres.
The wet tyres will not need to be marked with a tyre sticker and will not be considered in the total number of tyres available for use.
During the preliminary technical inspection, the adhesive stickers used for marking the tyres will be delivered to the teams. Each team will be responsible of marking their tyres.
The Technical Stewards may perform random controls during the qualifying practices.
If the riders are shown a red flag during the practice, or the race/s, the Permanent Race Direction is allowed to authorize the use of a supplementary tyre. All checked tyres must be easily identifiable with a colour marking or a numerical system.
In case of a dispute, the Technical Director will be the sole judge to take the appropriate decision.

2.3.3.10 Numbers and backgrounds

1. The front plate must be located in the middle of the fairing's front or on the side facing the official time keeping staff.
2. Rear or side numbers are optional. If they are fitted, must govern the same rules as the front.
3. The dimensions for the number plates must be: 140mm x 25mm minimum. Numbers from 1 to 9 can be wider. Two-digit numbers must have a separation (min. 10mm) between digits so the background colour is visible between digits. Only numbers between 1 and 99 will be admitted.
4. Backgrounds must be of one single colour over an area large enough to provide a minimum clear area of 25 mm around the numbers.
5. Numbers cannot overlap.
6. In case of a dispute concerning the legibility of numbers, the decision of the Technical Director will be final.

The numbers and backgrounds will be as follows:

| | Background | Number |
|--------|------------|--------|
| Moto3™ | Black | White |

2.3.4 General

2.3.4.1 Fuel and oil

Refer to [Appendix 10](#)

2.3.4.2 Rider's Safety Equipment

Refer to [Appendix 11](#) and ~~12~~

2.3.4.3 Procedures for Technical Control

Refer to [Appendix 12](#)

Moto3™ Junior Appendix 1

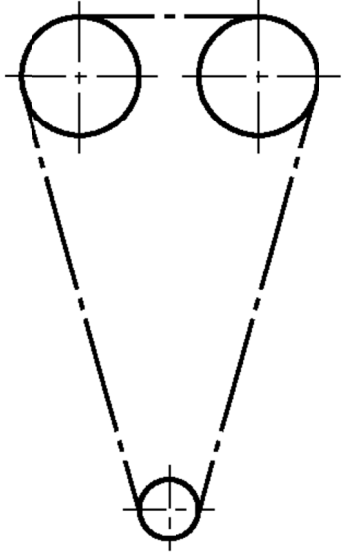

A) Simple chain drive

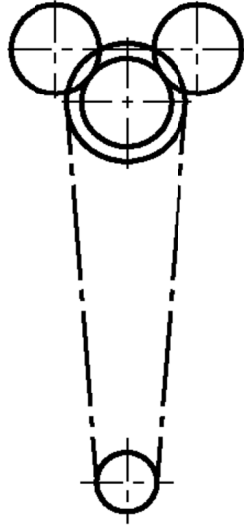

B) Chain drive + upper gear

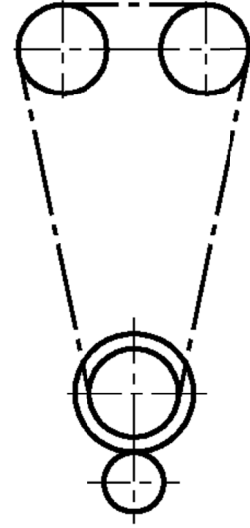

C) Chain drive + lower gear

Moto3™ Junior Appendix 2

Compulsory Engine Management features

| | |
|---------------------------------|--|
| Ignition | Must be of the inductive type. Maximum ignition coil current must be less than 30A |
| Throttle Position Sensor | Voltage output must be 0 – 5V |
| Crankshaft Pickup Sensor | Must be of the inductive type. Voltage at 300rpm must be at least 0.8V, and maximum voltage less than 100V |
| Camshaft Pickup Sensor (if any) | Must be of the Hall-effect type. “0” voltage must be less than 0.5V, “1” voltage must be $4.5V \pm 0.5V$ |
| Battery | Is compulsory. Must be in the 8 – 16.5V range (measured at the voltage acquisition channel) to ensure proper engine management function |
| Datalogger Download Connector | Must be type: Lemo PEN.1F.308.XLM or one completely compatible with this. Connected as detailed in Dell’Orto online documentation, http://www.dellorto-pe.com/ |
| UEGO O ² Sensor | Bosch LSU 4.9 |
| Dashboard | Dell’Orto DoDash. Refer to website http://www.dellorto-pe.com/ |

Moto3™ Junior Appendix 3

Recommended Engine Management features

(NB. Different design choices must be agreed separately with the official ECU supplier)

| | |
|--|--|
| Idle Speed Stepper Motor | Dell'Orto. Refer to website http://www.dellorto-pe.com/ |
| Timing Option 1 Crankshaft Pickup only | Crankshaft timing pattern is "n-2" type, where "n" can be between 12 and 60. For optimum performance it is recommended that the first tooth after the missing teeth corresponds to TDC (top dead centre) |
| Timing Option 2 Crankshaft and Camshaft Pickups | Crankshaft timing wheel has between 12 and 60 teeth, and the camshaft timing pattern is one single tooth |
| ECU Mounting | Dell'Orto ECU Safety Fixing Kit. Refer to website http://www.dellorto-pe.com/ |
| Ignition Module | Dell'Orto IGBT Ignition Module. Refer to website http://www.dellorto-pe.com/ |

Moto3™ Junior Appendix 4

Initial ECU Mapping and Set Up Procedure

The official ECU start-up procedure is to ensure manufacturers will be supplied with the official ECU with an initial map to suit their engine in time for the first official Moto3™ tests of the season. The initial map is intended for safe and trouble-free engine function, and not maximum performance. Performance mapping is the responsibility of the engine manufacturer or the Team.

NB. Detailed information on engine control strategies for Moto3™ engine manufacturers is available from the ECU supplier, upon completion of a non-disclosure agreement. Refer to the website: <http://www.dellorto-pe.com/>

For an engine design to be eligible for the Moto3™ class, one of the following two options for the ECU start-up procedure must be followed:

| | |
|---|---|
| OPTION 1 Initial Mapping and Set Up by ECU Supplier | Manufacturers will be guaranteed supply of the official ECU with initial maps to suit their engine before the first Moto3™ official tests of the season, provided that: |
| By October 15 th of the year preceding first entry in Moto3™ | <ol style="list-style-type: none">1. the completed Moto3™ Engine Manufacturer Entry Form is submitted to the organisers. (form available at http://www.fim-live.com/en/sport/official-documents-ccr/other-documents/)2. two complete working engines (including throttle body, idle bypass actuator, transmission, sensors, spark plugs, wiring harness with ECU connector) and one complete airbox, cooling system and exhaust are delivered to the ECU supplier for mapping tests. Engines and parts will be returned by January of the following year.3. a deposit of 10,000 €uros is lodged with the official ECU supplier. |
| OPTION 2 Initial Mapping and Set Up by Engine Manufacturer | Engine Manufacturers can make an agreement with the ECU supplier to carry out their own Initial mapping procedure, with the following conditions: |

Appendix 5

MOTO2™ EUROPEAN CHAMPIONSHIP TECHNICAL SPECIFICATIONS

Manufacture engine motorcycle: Honda Motor Co., Ltd.

Model: CBR600RR 07 – 20 (Type PC40x)

EVERYTHING THAT IS NOT AUTHORISED AND PRESCRIBED [IN THE POINTS 3.1, 3.2 & 3.6](#) IS STRICTLY FORBIDDEN.

3.1 Engine

3.1.1

It's compulsory to use the Honda CBR 600 RR model 2007, 2008, 2009, 2010, 2011, 2012, 2013, 2014, 2015, 2016, 2017, 2018, 2019, 2020 (Type PC40x)

3.1.2

Cam sprockets and its screws may be mechanized or replaced.

3.1.3

“Pair” valve may be removed. To do this, it's allowed to install flat metal plates in the head cover.

3.1.4

Electric starter may be removed. It's allowed to remove the gears of this electric starter, too.

3.1.5

The cylinder head gasket may be changed.

3.1.6

The oil filter may be changed.

3.1.7

All lateral covers/engine cases containing oil and which could be in contact with the ground during a crash, must be protected by a second cover made from composite materials, type carbon or Kevlar®, aluminium, plastic or steel plates and/or bars are also permitted. All these devices must be designed to be resistant against sudden shocks and must be screwed to the crankcase.

3.1.8

Coolant hoses and fittings may be changed to suit individual radiator designs.

3.1.9

If necessary, the cam head can be planned and repair valve seats to allow reuse. This planned cannot exceed 0.1 mm. recommended by the engine manufacturer for this job.

3.1.10

The only pistons allowed, are the originals. The “oversized” pistons provided by the manufacturer are not allowed.

3.1.11

It's authorized to change the screw that fixes the pick-up (Part code 90013-430-000).

3.1.12

No other change that is not specified in this article is allowed.

3.1.13

In the case of dispute over modifications, the decision of the Technical Director will be final.

3.2 Fuel System

3.2.1

The throttle bodies must remain as originally produced by the manufacturer for the homologated engine.

3.2.2

Modifications to the fuel pressure regulator are not allowed. The fuel tank gauge assembly (ie. float, arm and support bracket) of the standard fuel pump may be removed.

3.2.3

The insulators that attach the throttle body to the head cannot be modified or changed.

3.2.4

The air box must remain as originally produced by the manufacturer on the homologated machine, including the secondary injectors.

3.2.5

The air filter element may be modified or replaced.

3.2.6

The air box drains must be sealed (safety wired).

3.2.7

All motorcycles must have a closed breather system. All the oil breather lines must be connected and discharge in the airbox.

3.2.8

Only the standard airbox may be used. No modifications, alterations or additions to this airbox are allowed, except those described below:

- a) The intake ducts, ahead of the air filter, may be changed to suit individual chassis designs.
- b) The resonance chambers on top of the airbox lid may be changed, modified or removed, either together with the top cover they are attached to, or the top cover may be left in place. They may be replaced by a blanking cover approximately flat in shape. The total airbox volume, from the filter back, may not be increased from the original. Refer to Diagram 4 at the end of the Moto2™ Appendix.
- c) A catch-tank may be fitted in the engine breather between the cam cover and airbox. The catch tank is solely for the purpose of collecting engine fluids, no other functions (such as pressure modification) are permitted and breather connections may only be directly between the cam cover, catch tank and airbox. The catch tank and

connections must be visible for inspection at all times (that is, not permanently built into the chassis or other parts).

- d) The airbox can be externally covered with an isolation material.

3.2.9

Only air or air/fuel is allowed between combustion chamber and intake air ducts.

3.2.10

The injectors must remain standard units as on the homologated engine.

3.2.11

Bell mouths may be modified or replaced as originally produced by the manufacturer for the homologated machine.

3.2.12

The throttle control valve must be controlled exclusively by mechanical means (ie. twistgrip and cable) operated by the rider only. No interruption of the mechanical connection between the rider's input and the throttle valve is allowed, and no devices may be added to the throttle cable system or to the standard throttle body to affect or control throttle valve movement.

3.2.13

Only fuel of the current year from the appointed fuel supplier is permitted. This fuel will be available at all official events, and will conform to the FIM specification. Use of this fuel without any addition or alteration is mandatory during the entire event (free practices, qualifying practices, warm-up and races). Also refer to [Appendix 10](#).

3.2.14

In the Moto2™ class fuel on the motorcycle must not be below the prevailing ambient temperature, as measured by the Technical Director. Other than a simple removable fuel tank cover, the use of any device on the motorcycle to artificially decrease the fuel temperature below ambient temperature is forbidden.

3.2.15

Any quality of oil may be used.

3.3 Exhaust System

Exhaust

- a) The outlet of the exhaust must not extend behind a line drawn vertically through the edge of the rear tyre.
- b) For safety reasons the exposed edge of the exhaust pipe outlet must be rounded to avoid any sharp edges
- c) Variable length exhaust systems are not permitted.
- d) Exhaust Gas Recirculation (EGR) systems are not permitted.

Noise Test

Also refer to [Appendix 12](#).

3.3.1

Noise limit is a maximum of 115 dB/A, measured in a static test at 5.500rpm

3.4 Cooling System

3.4.1

Design and construction of the cooling system is free.

3.4.2

The standard engine oil cooler is mandatory, and additional oil coolers are not permitted.

3.5 Control Systems

3.5.1

The use of hydraulic and/or pneumatic pressurized powered systems is not allowed. All hydraulic systems on the motorcycle must be powered only by the rider's manual inputs with the following clarifications:

- Normal hydraulic hand/foot controls such as master/slave cylinders for brakes/clutch are allowed.
- Oil/water pumps for engine lubricating/cooling are allowed.
- The use of engine lubricating oil for any purpose other than lubrication and cooling (such as powered hydraulic systems) is not allowed.

3.5.2.

Variable valve timing and variable valve lift systems, driven by hydraulic and/or electric/electronic systems are not permitted.

3.6 Clutch and Transmission

3.6.1

Clutch type (wet) and the way of operation (by cable) must remain as homologated.

3.6.2

Friction and drive discs may be changed.

3.6.3

Clutch springs may be changed.

3.6.4

The clutch basket (outer) may be changed.

3.6.5

The original clutch assembly may be modified for back torque limiting capabilities (slipper type).

- 3.6.6 It is allowed to change to an aftermarket clutch with back torque limiting capabilities (slipper type).
- 3.6.7 The use of electro-mechanical or electro-hydraulic actuating systems are not allowed.
- 3.6.8 An external quick-shift system on the gear selector (including wire and potentiometer) may be added.
- 3.6.9 Countershaft sprocket, rear wheel sprocket, chain pitch and size can be changed.
- 3.6.10 Clutch cover can be changed or modified, to fit a new clutch.
- 3.6.11 Other modifications to gearbox or selector mechanism are not allowed.

3.7 Ignition and Electronics

- 3.7.1 Ignition/engine control system (ECU) may be modified or changed.
- 3.7.2 The traction control systems are not allowed.

3.8 Datalogger

- 3.8.1 The data acquisition may be added.

3.9 Chassis

3.9.1 Weights

- 3.9.1.1 The following are the minimum weights permitted:

Moto2™ motorcycle + rider: 217 kg

- 3.9.1.2 Ballast may be added to achieve the minimum weights.

- 3.9.1.3 Weight may be checked at the initial technical control, but the main control of weight will be made at the end of practice sessions or at the end of the race. The weight of the motorcycle will be that measured in the form that the motorcycle participated, with fuel tank on and including normal levels of oil and water, and all additional equipment

attached to the motorcycle, for example timekeeping transponders, camera equipment, electronic datalogging equipment etc.

For this class the weight checked will be the total of the rider with full protective clothing plus the weight of the motorcycle. Random weight controls may be carried out during practice in a designated weighing area. Also refer to [Appendix 12](#).

3.9.2 Safety and Construction criteria.

3.9.2.1

The chassis must be a prototype, the design and construction of which is free within the constraints of the FIM Grand Prix Technical Regulations. The main frame, swingarm, fuel tank, seat and fairing/bodywork from a non-prototype (ie. series production road-homologated) motorcycle may not be used. Also refer to [Appendix 8](#).

3.9.2.2

Throttle twistgrips must close automatically when released.

3.9.2.3

Steering:

- a) Handlebars must have a width of not less than 450 mm and their ends must be solid or rubber covered. The width of the handlebar is defined as the width measured between the outside of the handlebar grips or throttle twist grips
- b) There must be at least 15 degrees of movement of the steering each side of the centre line.
- c) Stops must be fitted to ensure a clearance of at least 30 mm between the handlebar and the fuel tank frame and/or bodywork when at the extremes of steering lock.

3.9.2.4

Footrests must have rounded ends with a minimum solid spherical radius of 8 mm.

3.9.2.5

Handlebar levers must not be longer than 200 mm measured from the pivot point.

3.9.2.6

Clearances:

- a) The motorcycle, unloaded, must be capable of being leaned at an angle of 50 degrees from the vertical without touching the ground, other than with the tyre.
- b) There must be a clearance of at least 15 mm around the circumference of the tyre at all positions of the motorcycle suspension and all positions of the rear wheel adjustment.

3.9.2.7

Any breather pipe from the engine or gearbox must discharge into the airbox and/or suitable container.

3.9.2.8

A chain guard must be fitted in such a way as to prevent trapping between the lower drive chain run and the final drive sprocket at the rear wheel.

3.9.2.9

Lateral engine covers containing oil and which could be in contact with the ground during a crash, should be protected by a second cover made from composite materials, e.g. nylon, carbon or Kevlar®. Plates and/or bars from aluminium or steel are also permitted. All these devices must be designed to be resistant against sudden shocks and abrasion and must be fixed properly and securely. Such protection is mandatory in the Moto2™ class.

3.9.3 Timing Transponders

Please refer to Appendix 9

3.9.4 Rear Safety Light

All motorcycles must have a functioning red light mounted at the rear of the machine, to be used in rain or low visibility conditions. The team must ensure that the light is switched on whenever a rain tyre is fitted on the motorcycle.

Lights must comply with the following:

- a) The lighting direction must be parallel to the centre line of the motorcycle (running direction) and it must be clearly visible from the rear, at least 15 degrees to both the left and right sides of the centre line of the motorcycle.
- b) It must be safely mounted on the very end of seat/rear bodywork and approximately on the centre line of the motorcycle. In case of dispute over the mounting position or visibility of the Rear Safety Light, the decision of the Technical Director will be final.
- c) The power output/luminosity must be equivalent to approximately 10-15W (incandescent) or 0,6-5W (led).
- d) Be able to be switched on and off by the rider when seated on the machine
- e) The safety light power supply may be separated from the motorcycle main wiring and battery.

3.10 Brakes

3.10.1

Motorcycles must have a minimum of one brake on each wheel that is independently operated.

3.10.2

In the Moto2™ class, only brake discs of ferrous materials are allowed.

3.10.3

In all classes, the proportion of ceramic composite materials in brake discs must not exceed 2% by mass.

Ceramic materials are defined as inorganic, non metallic solids (e.g. Al₂O₃, SiC, B₄C, Ti₅Si₃, SiO₂, Si₃N₄).

Refer to Art. 3.16.4 and 3.16.5 for other permitted materials in brake component construction.

3.10.4

Motorcycles must be equipped with brake lever protection, intended to protect the handlebar brake lever(s) from being accidentally activated in case of collision with another machine. Acceptable protection includes the fairing extending sufficiently to cover the brake lever, as viewed from the front.

Such devices must be strong enough to function effectively and designed so that there is no risk for the rider to be injured or trapped by it, and it must not be considered a dangerous fitting (at the sole discretion of the Technical Director).

In case the brake lever protection is attached to any part of the braking system (e.g. brake master cylinder), then the brake system manufacturer must officially confirm in writing to the Technical Director that the device does not interfere with the proper brake operation.

3.10.5

Anti-lock Brake Systems (ABS) are not permitted. Braking inputs must be powered and controlled solely by the rider's manual inputs. Conventional hydraulic hand/foot controls such as master/slave cylinders for brake systems are allowed (refer also to Art. 5.1 Control Systems) but no increase or control of brake pressure by electronic or mechanical systems apart from the rider's direct manual inputs are allowed. Specifically, brake systems designed to prevent the wheel from locking when the rider applies the brake are forbidden.

3.11 Suspension and Dampers

3.11.1

Electric/electronic controlled suspension, ride height and steering damper systems are not allowed. Adjustments to the suspension and steering damper systems may only be made by manual human inputs and mechanical/hydraulic adjusters.

3.12 Fuel Tanks

3.12.1

Fuel caps must be leak proof and have a positive closing device.

3.12.2

Fuel tank breather pipes must include a non-return valve. Fuel tank breather pipes must discharge into a suitable container **or containers**, with a minimum capacity of 200 cc.

3.12.3

Fuel tanks of all construction types must be filled with fire retardant material or be lined with a fuel cell bladder.

3.12.4

Except for the case that a fuel tank is fixed on the chassis with bolts, all fuel lines from the fuel tank to the engine/injector system should have a self sealing breakaway valve. This valve must separate at less than 50% of the load required to break any part of the fuel line or fitting or to pull it out of the fuel tank.

3.12.5

Refuelling may only be carried out from an unpressurised container, and the motorcycle fuel tank may not be artificially pressurised above atmospheric pressure at any time. It is allowed to vent the fuel tank to the atmosphere via the airbox in order to equalise pressure in the airbox and fuel tank.

3.13 Bodywork

Note: please also refer to [Appendix 8](#).

3.13.1

The windscreen edge and the edges of all other exposed parts of the streamlining must be rounded.

3.13.2

The maximum width of bodywork must not exceed 600 mm. The width of the seat or anything to its rear shall not be more than 450 mm (exhaust pipes excepted).

3.13.3

Bodywork must not extend more than 150 mm beyond a line drawn vertically from the centre of the front wheel spindle and a line drawn vertically at the rearward edge of the rear tyre. The suspension should be fully extended when the measurement is taken.

3.13.4

When viewed from the side, it must be possible to see:

- a) At least 180 degrees of the rear wheel rim.
- b) The whole of the front rim, other than the part obscured by the mudguard, forks, brake parts or removable air-intake.
- c) The rider, seated in a normal position with the exception of the forearms.

Notes: No transparent material may be used to circumvent the above rules. Covers for brake parts or wheels are not considered to be bodywork obstructing the view of wheel rims in regard to the above rules.

3.13.5

No part of the motorcycle may be behind a line drawn vertically at the edge of the rear tyre.

3.13.6

The seat unit shall have a maximum height of the (approximately) vertical section behind the rider's seating position of 150 mm. The measurement will be taken at a 90° angle to the upper surface of the flat base at the rider's seating position, excluding any seat pad or covering.

3.13.7

Mudguards are not compulsory. When fitted, front mudguards must not extend:

- a) In front of a line drawn upwards and forwards at 45 degrees from a horizontal line through the front wheel spindle.
- b) Below a line drawn horizontally and to the rear of the front wheel spindle.

The mudguard mounts/brackets and fork-leg covers, close to the suspension leg and wheel spindle, and brake disc covers are not considered part of the mudguard.

3.13.8

Device or shapes protruding from the fairing or bodywork and not integrated in the body streamlining (eg. wings, fins, bulges, etc.), that may provide an aerodynamic effect (eg. providing downforce, disrupting aerodynamic wake, etc.) are not allowed.

The Technical Director will be the sole judge of whether a device or fairing design falls into the above definition.

Moving aerodynamic devices are prohibited.

3.13.9

The lower fairing has to be constructed to hold, in case of an engine breakdown, at least half of the total oil and engine coolant capacity used in the engine (minimum 5 litres). This measurement should be taken with the fairing fitted to the motorcycle, whilst both wheels are on the ground and the motorcycle is upright at 90° to the horizontal.

The lower fairing may incorporate a maximum of two holes of Ø 25 mm diameter in the front lower area. This hole must remain closed in dry conditions and must be only opened in wet race conditions.

3.14 Wheel Rims

3.14.1

Permitted wheel rim sizes are as follows:

| | Front | Rear |
|--------|------------------|------------------|
| Moto2™ | 3.75" x 17" only | 6.00" x 17" only |

3.14.2

In this class, composite construction wheels (including carbon fibre reinforced, glass fiber reinforced, and similar) are not permitted. The permitted materials for wheel construction are magnesium and aluminium alloys.

3.15 Tyres

3.15.1

Only tyres from the official tyre supplier may be used in a Moto2™ and each team must sign a contract.

3.15.2

The tyre specifications available at each event will be determined by the Championship Promoter. Only homologated tyres in each event are permitted.

3.15.3

The use of any device on the wheel to adjust the tyre pressure whilst on track is prohibited.

3.15.4

The maximum number of slick tyres allowed to use during the qualifying practices are THREE (3). Only the rear slick tyres need to be marked with a tyre sticker. The rain

tyres will not need to be marked with a tyre sticker and will not be considered in the total number of tyres available for use.

3.15.5

A maximum of ONE (1) rear slick tyre per race may be used. Only the race rear slick tyres shall be marked with a code differentiable qualifying tyres. The rain tyres will not need to be marked with a tyre sticker and will not be considered in the total number of tyres available for use.

3.15.6

During the preliminary technical inspection, the adhesive stickers used for marking the tyres will be delivered to the teams. Each team will be responsible of marking their tyres. Each team will be responsible of marking their tyres.

3.15.7

The Technical Stewards and /or the official tyre supplier may perform random controls during the qualifying practices and races.

3.15.8

If the riders are shown a red flag during the practice or the race/s, the Race Direction is allowed to authorize the use of a supplementary tyre. All checked tyres must be easily identifiable with a colour marking or a numerical system.

3.15.9

In case of a technical problem, the Technical Director will take a decision about the problem.

3.16 Materials

NB. "X-based alloy" or "X materials" here means the element X (e.g. Fe, for ferrous or iron-based alloy) must be the most abundant element in the alloy, on a % w/w basis.

3.16.1

The use of titanium in the construction of the following parts is forbidden:

- The frame/chassis, excluding bolts and fasteners (the decision of the Technical Director will be final when determining what constitutes a part of the chassis).
- The swinging arm, excluding bolts and fasteners.
- The swinging arm spindles.
- The wheel spindles (for wheel spindles, the use of light alloys is also forbidden).
- The handlebars.
- The front suspension inner and outer tubes and bottoms (ie. axle mounting point).
- The shock absorber piston shaft and damper tube.

3.16.2

The basic structure of the crankshaft and camshafts must be made from ferrous materials, steel or cast iron. Inserts of a different material are allowed in the crankshaft for the sole purpose of balancing.

3.16.3

Pistons, cylinder heads and cylinder blocks may not be composite structures which use carbon or aramid fibre reinforcing materials.

3.16.4

Brake calipers must be made from aluminium materials with a modulus of elasticity no greater than 80 Gpa.

3.16.5

All connectors from the brake hose to the brake calipers (front and rear) and the brake master cylinders must have structural components (*) manufactured from either steel or titanium alloys with a tensile strength no less than 500 Mpa.

* Brass connectors are permitted for rear brake hoses only.

3.16.6

No parts of the motorcycle or engine may be made from metallic materials which have a specific modulus of elasticity greater than 50 Gpa / (g/cm³).

3.16.7

The use of MMC (Metal Matrix Composite) and FRM (Fibre Reinforced Metal) materials is forbidden.

3.17 General

3.17.1

Number of motorcycles (Also refer to [Appendix 12](#))

3.17.1.1

Teams may present only one motorcycle per rider for Technical Control.

3.17.1.2

If during the official practice sessions a motorcycle suffers any damages that are difficult to repair in the circuit, the Technical Director could allow a second motorcycle to go under the technical inspection. The process of authorizing a new machine is not possible during a practice session. Once the starting procedure is initiated, it isn't possible to verify a second motorcycle, neither in case of detention by red flag. In case of events with two races, once the first race is finished, the Technical Director may allow the request for verification of a second motorcycle.

3.17.2

Once the official practice sessions have started, only the motorcycle that has gone under the technical inspection will be allowed to be inside the box.

3.18 Numbers and backgrounds

3.18.1

The front plate must be located in the middle of the fairing's front or on the side facing the official time keeping staff.

3.18.2

Rear or side numbers are optional. If they are fitted, must govern the same rules as for front.

3.18.3

The dimensions for the number plates must be: 140mm x 25mm minimum. Numbers from 1 to 9 can be wider. Two-digit numbers must have a separation (min. 10mm) between digits so the background colour is visible between digits. Only numbers between 1 and 99 will be admitted.

3.18.4

Backgrounds must be of one single colour over an area large enough to provide a minimum clear area of 25mm around the numbers.

3.18.5

In case of a dispute concerning the legibility of numbers, the decision of the Technical Director will be final.

3.18.6

Numbers cannot overlap.

3.18.7

The numbers and backgrounds will be as follows:

| | Background | Number |
|--------|------------|--------|
| Moto2™ | Yellow | Black |

3.19 Fuel and oil

Refer to [Appendix 10](#)

3.20 Rider's Safety Equipment

Refer to [Appendix 11](#) and ~~12~~

3.21 Procedures for Technical Control

Refer to [Appendix 12](#)

Diagram 4

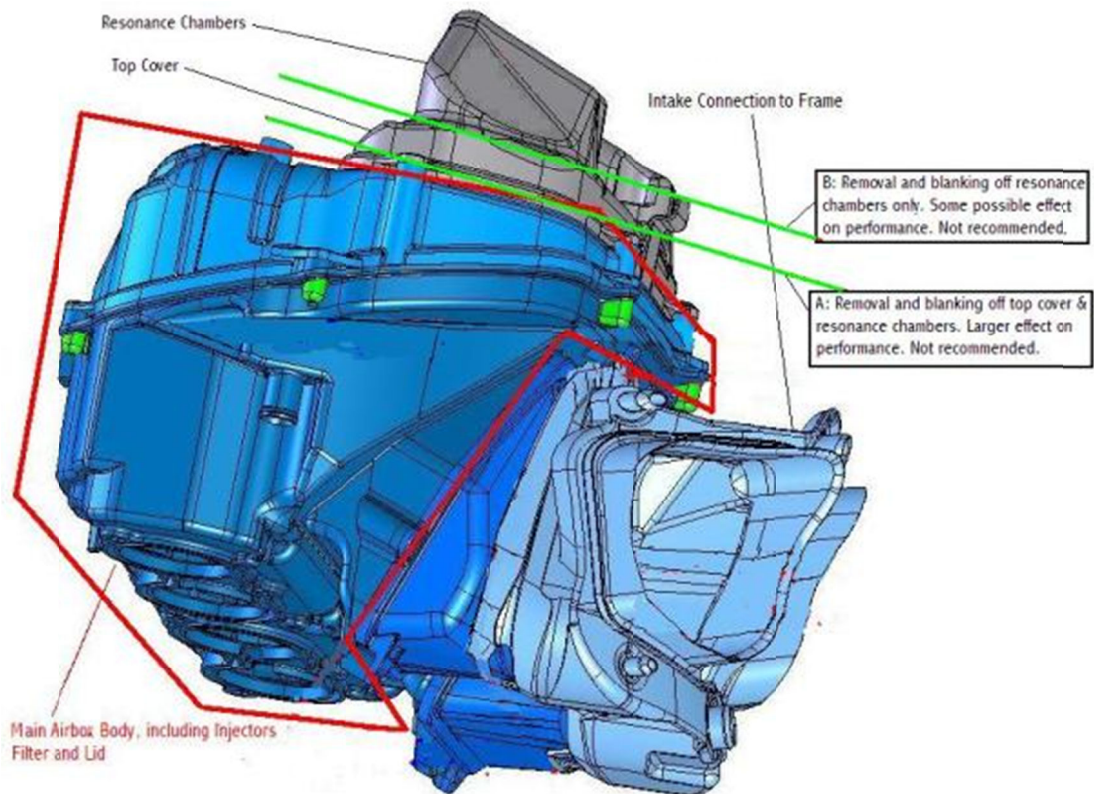

Appendix 6

4.6 SUPERSTOCK 600 TECHNICAL SPECIFICATIONS

The following rules are intended to permit limited changes to the homologated motorcycle in the interests of safety and improved competition between various motorcycle concepts.

EVERYTHING THAT IS NOT AUTHORISED AND PRESCRIBED IN THIS RULE IS STRICTLY FORBIDDEN

If a change to a part or system is not specifically allowed in any of the following articles, then it is forbidden.

Superstock motorcycles require an FIM homologation (see FIM Homologation procedure for Superstock, Supersport and Superbike motorcycles available on the FIM Web site: www.fim-live.com/library). All machines must be normally aspirated. All motorcycles must comply in every respect with all the requirements for road racing as specified in these Technical Regulations, unless they are already equipped as such on the homologated model.

Once a motorcycle has obtained the homologation, it may be used for racing in the corresponding class for a maximum period of 8 years. Or until such time that the homologated motorcycle is disqualified by new rules or changes in the technical specifications of the corresponding class.

The appearance from both front, rear and the profile of Superstock 600 motorcycles must (except when otherwise stated) conform to the homologated shape (as originally produced by the manufacturer). The appearance of the exhaust system is excluded from this rule.

Eligible models are listed on the FIM website (www.fim-live.com)

4.6.1 Motorcycle specifications

All parts and systems not specifically mentioned in the following articles must remain as originally produced by the manufacturer for the homologated motorcycle

4.6.2 Displacement capacities

The following engine configurations comprise the Superstock 600 class:

Over 400 cc up to 600 cc 4-stroke 4 cylinders

Over 500 cc up to 675 cc 4-stroke 3 cylinders

Over 600 cc up to 750 cc 4-stroke 2 cylinders

The displacement capacity, bore and stroke (new), must remain at the homologated size.

4.6.3 Balancing various motorcycle concepts

In order to equalize the performance of motorcycles with different engine configurations, changes in the minimum weight may be applied according to their respective racing performances. The decision about applying a handicap system to a respective class is taken by the FIM CEV Commission at any time.

The application of the handicap will follow the system like described in the Superbike regulations but will be adapted to this class.

4.6.4 Minimum Weights

Refer also to [Appendix 12](#).

The minimum weight for each model is calculated by FIM by determining the “dry weight” of the homologated motorcycle.

The ‘dry’ weight of a homologated motorcycle is defined as the total weight of the empty motorcycle as produced by the manufacturer (after removal of fuel, vehicle number plate, tools and main stand and side stand when fitted but with oil and radiator liquid at prescribed level). To confirm the ‘dry’ weight a minimum of three (3) motorcycles are weighed and compared. The result will be rounded off to the nearest digit.

The minimum weight for each model will be calculated by reducing the dry weight” of the motorcycle in 12 kg.

At any time of the event, the weight of the whole machine (including the tank and its contents) must not be lower than the minimum weight.

There is no tolerance on this minimum weight.

During the final technical inspection at the end of the race, the selected motorcycles will be weighed in the condition they finished the race, and the established weight limit must be met in this condition. Nothing may be added to the motorcycle. This includes all fluids.

During the practice and qualifying sessions, riders may be asked to submit their motorcycle to a weight control. In all cases the rider must comply with this request.

The use of ballast is allowed to stay over the minimum weight limit and may be required due to the handicap system. The use of ballast and weight handicap must be declared to the Technical Director at the preliminary checks.

4.6.5 Numbers and number plates

The background colours and figures (numbers) for Superstock 600 are yellow background with black numbers:

The sizes for all the front numbers are:

| | |
|-------------------------------|--------|
| Minimum height: | 140 mm |
| Minimum width: | 80 mm |
| Minimum stroke: | 20 mm |
| Minimum space between numbers | 10 mm |

The size for all the side numbers is:

| | |
|-----------------|--------|
| Minimum height: | 120 mm |
| Minimum width: | 70 mm |
| Minimum stroke: | 25 mm |

Minimum space 10 mm
between numbers

The allocated number (& plate) for the rider must be affixed on the machine as follows:

- a) once on the front, either in the centre of the fairing or slightly off to one side. The number must be centred on the yellow background with no advertising within 25mm in all directions.
- b) once on each side of the motorcycle. Alternatively, once across the top of the rear seat section with the top of the number towards the rider. The rear and side numbers are optional. The preferred location for the numbers on each side of the motorcycle is on the lower rear portion of the main fairing near the bottom. The number must be centered on the yellow background.
- c) The numbers must use sufficiently legible fonts.
- d) The background colour must be clearly visible around all edges of the number (including outline). Reflective or mirror type numbers are not permitted.
- e) Numbers cannot overlap.
- f) No machine may enter the circuit if it does not meet the above regulations. If the rider does enter the circuit then no lap times will be recorded and Race Direction will at their discretion black flag the rider.

In case of a dispute concerning the legibility of numbers, the decision of the Technical Director will be final.

4.6.6 Fuel

Refer to [Appendix 10](#).

4.6.7 Tyres

Only tyres from the official tyre supplier may be used in the Superstock 600 FIM CEV and each team must sign a contract.

The tyre specifications available at each event will be determined by the Championship Promoter. Only homologated tyres in each event are permitted.

The maximum number of rear slick tyres allowed to use during the qualifying practices are THREE (3). Only the rear slick or "road legal" tyres need to be marked with a tyre sticker.

A maximum of ONE (1) rear "dry" tyre per race may be used. Only the race rear "dry" tyres shall be marked with a code differentiable qualifying tyres. The wet tyres will not need to be marked with a tyre sticker and will not be considered in the total number of tyres available for use.

The wet tyres will not need to be marked with a tyre sticker and will not be considered in the total number of tyres available for use.

During the preliminary technical inspection, the adhesive stickers used for marking the tyres will be delivered to the teams. Each team will be responsible of marking their tyres. Each team will be responsible of marking their tyres.

The Technical Stewards and /or the official tyre supplier may perform random controls during the qualifying practices and races. If the riders are shown a red flag during the practice or the race/s, the Permanent Race Direction is allowed to authorize the use of a supplementary tyre. All checked tyres must be easily identifiable with a colour marking or a numerical system.

In case of a technical problem, the Technical Director will take a decision about the problem.

4.6.8 Engine

4.6.8.1 Fuel Injection System

- a. The original homologated fuel injection system must be used without any modification.
- b. The fuel injectors must be stock and unaltered from the original specification and manufacture.
- c. Air Funnels must remain as originally produced by the manufacturer for the homologated motorcycle.
- d. Butterfly valves cannot be changed or modified.
- e. All the parts of the variable intake tract device must remain and operate exactly as homologated. They cannot be added if not fitted to the homologated machine.
- f. Air and air/fuel mixture must go to the combustion chamber exclusively through the throttle bodies.
- g. Electronically controlled throttle valves, known as 'ride-by-wire', may be only used if the homologated model is equipped with the same system.

4.6.8.2 Cylinder Head

- a. Must be the originally fitted and homologated part with no modification allowed.
- b. The gaskets may be changed.
- c. Valve spring shims may be changed freely.
- d. Only normal maintenance interventions as prescribed by the Manufacturer in the service manual of the motorcycle are authorized.
- e. The exhaust air bleed system must be blocked and the external fittings on the cam cover(s) may be replaced by plates.

4.6.8.3 Camshaft

- a. Must be the originally fitted and homologated part with no modification allowed.
- b. At the technical checks: for direct cam drive systems, the cam lobe lift is measured; for non direct cam drive systems (i.e. with rocker arms), the valve lift is measured.

4.6.8.4 Cam sprockets or Gears

- a. Cam Sprockets may be slotted to allow the adjustment of cam timing.
- b. Pressed on cam sprockets may be replaced with an adjustable boss and cam sprocket.
- c. The cam chain and tensioner must remain as homologated.

4.6.8.5 Cylinders

Must be the originally fitted and homologated part with no modification allowed.

4.6.8.6 Pistons

Must be the originally fitted and homologated part with no modification allowed.

4.6.8.7 Piston rings

Must be the originally fitted and homologated part with no modification allowed.

4.6.8.8 Piston pins and Clips

Must be the originally fitted and homologated part with no modification allowed.

4.6.8.9 Connecting rods

Must be the originally fitted and homologated part with no modification allowed

4.6.8.10 Crankshaft

Must be the originally fitted and homologated part with no modification allowed

4.6.8.11 Crankcase / Gearbox housing

- a. Crankcases must remain as homologated. No modifications are allowed (including painting, polishing and lightening).
- b. It is not allowed to add a pump used to create a vacuum in the crankcase. If a vacuum pump is installed on the homologated motorcycle then it may be used only as homologated.

4.6.8.11.1 Lateral covers and protection

- a. Lateral (side) covers may be altered, modified or replaced. If altered or modified, the cover must have at least the same resistance to impact as the original one. If replaced, the cover must be made in material of same or higher specific weight and the total weight of the cover must not be less than the original one.
- b. All lateral covers/engine cases containing oil and which could be in contact with the ground during a crash, must be protected by a second cover made from metal, such as aluminium alloy, stainless steel or steel, composite covers are not permitted.
- c. The secondary cover must cover a minimum of 1/3 of the original cover. It must have no sharp edges to damage the track surface.

- d. Plates or crash bars made from aluminium or steel also are permitted in addition to these covers. All of these devices must be designed to be resistant against sudden shocks, abrasions and crash damage.
- e. FIM approved covers will be permitted without regard of the material or its dimensions.
- f. These covers must be fixed properly and securely with a minimum of three (3) case cover screws that also mount the original covers/engine cases to the crankcases.
- g. Oil containing engine covers must be secured with steel bolts.
- h. The Technical Director has the right to refuse any cover not satisfying this safety purpose.

4.6.8.12 Transmission / Gearbox

- a. Must be the originally fitted and homologated part with no modification allowed except:
 - i) The positive neutral selector mechanism may be removed.
 - ii) Shift star/indexer spring, roller and detent may be replaced but must function as originally designed
- b. Quick-shift systems are allowed (including wire and potentiometer). Also refer to Art. 4.6.9.1 r.
- c. Countershaft sprocket, rear wheel sprocket, chain pitch and size may be changed.
- d. The sprocket cover may be modified or eliminated.
- e. Chain guard as long as it is not incorporated in the rear fender may be removed.

4.6.8.13 Clutch

- a. Must be the originally fitted and homologated part with no modification allowed.
- b. Only friction and drive discs may be changed, but their number must remain as original.
- c. Clutch springs may be changed.

4.6.8.14 Oil pumps and Oil lines

- a. Must be the originally fitted and homologated part with no modification allowed.
- b. Oil lines may be modified or replaced. Oil lines containing positive pressure, if replaced, must be of metal reinforced construction with swaged or threaded connectors.

4.6.8.15 Radiator, cooling system and oil coolers

- a. The only liquid engine coolants permitted is water.
- b. Protective meshes may be added in front of the oil and/or water radiator(s).
- c. The cooling system hoses and catch tanks may be changed.

- d. Radiator fan and wiring may be removed. Thermal switches, water temperature sensor and thermostat may be removed inside the cooling system.
- e. Radiator cap is free.
- f. An additional water radiator may be fitted but the appearance of the front, the rear and the profile of the motorcycle must not be changed. Extra mounting brackets to accommodate the additional radiator are permitted.
- g. The original heat exchanger (oil/water) may be replaced by an oil-cooler and its tubes separated from the cooling circuit. The original oil radiator (if fitted) may be replaced.

4.6.8.16 Air box

- a. The air box must remain as originally produced by the manufacturer on the homologated motorcycle.
- b. The air filter element may be modified or replaced but must be mounted in the original position.
- c. The air box drains must be sealed.
- d. All motorcycles must have a closed breather system. All the oil breather lines must be connected, may pass through an oil catch tank and must exclusively discharge in the airbox.
- e. No heat protection may be attached to the airbox.

4.6.8.17 Fuel supply

- a. Fuel pump and fuel pressure regulator must remain as homologated.
- b. The fuel pressure must be as homologated.
- c. Fuel lines from the fuel tank to the delivery pipe assembly (excluded) may be replaced and must be located in such a way that they are protected from crash damage.
- d. Quick connectors or dry break connectors may be used.
- e. Fuel vent lines may be replaced.
- f. Fuel filters may be added.

4.6.8.18 Exhaust system

- a. Exhaust pipes and silencers may be modified or changed. Catalytic converters must be removed.
- b. The number of the final exhaust silencer(s) must remain as homologated. The silencer(s) must be on the same side(s) of the homologated model.
- c. For safety reasons, the exposed edges of the exhausts pipe(s) outlet must be rounded to avoid any sharp edges.
- d. Wrapping of exhaust systems is not allowed except in the area of the rider's foot or an area in contact with the fairing for protection from heat.

- e. The noise limit for Superstock 600 be 107 dB/A (with a 3 dB/A tolerance after the race only)

4.6.8.19 Sound level control

Refer to [Appendix 12](#).

4.6.8.19.1 Sound limits in force:

Noise will be controlled at: Max. 107 dB/A measured at a mean piston speed of 11 m/sec.

4.6.8.19.2 Noise control

Due to the similarity of the piston stroke in different engine configurations within the capacity classes, the noise test will be conducted at a fixed RPM. For reference only, the mean piston speed at which the noise test is conducted is calculated at 11 m/sec.

| | 2 Cylinders | 3 Cylinders | 4 Cylinders |
|-------------|-------------|-------------|-------------|
| 600 c.c. | 5.500 RPM | 6.500 RPM | 7.000 RPM |
| To 750 c.c. | 5.500 RPM | 6.000 RPM | 7.000 RPM |

4.6.8.19.3 Noise control after the competition

In a competition which requires a final examination of machines before the results are announced, this examination can include a noise control measurement of at least the first three machines listed in the final classification. At this final test, there will be a 3 dB/A tolerance.

4.6.9 Electrics and Electronics

4.6.9.1 Ignition / Engine Control System (ECU)

- a. The engine control system (ECU) must be either:
 - i. The original system as homologated, with no change of software being allowed.
 - ii. The original system (with the production ECU and no change of software) (option i) may have external ignition and/or injection module/s added. The total combined retail price (software and tuning tools included) on sale to the general public cannot be higher than €3000 (VAT excluded). A special connector may be used to connect the module/s and the ECU.
 - iii. An approved "Superstock Kit" model with approved software (produced and/or approved by the motorcycle manufacturer) may be used. A special connector/adaptor may be used to connect the ECU(s) and the original wiring harness. The combined retail price of the full system including software, tuning tool, download / connection cable any activations, upgrades and wiring harness(s) must be less than:
 1. €3000 (VAT excluded) if the system excludes data logging
 2. €3750 (VAT excluded) if the system includes data logging.

The ECU (with software and activations) and harness parts must be individually priced and available separately. The separate ECU and harness total must respect the above limits.

- iv. Other "Superstock Kit" ECU(s) from other manufacturers may be used provided these have been homologated for other models of the category; Therefore, other manufacturers may use this "Superstock Kit" ECU for their own motorcycles provided these have been homologated for the relevant model.
- b. The software and the firmware must be supplied and approved by the machines manufacturer.
- c. The manufacturer must provide the FIM with the tools/software to perform software checks.
- d. Throughout the season the manufacturer may update the software and the updates must be made available simultaneously to all users of the system with no charge, updating by a team is not compulsory.
- e. Central unit (ECU) may be relocated.
- f. Corner by corner or distance/position based adjustments are not allowed.
- g. Optional equipment sold by the motorcycle Manufacturer for the homologated model is considered not homologated with the bike and must follow the requirements for approved electronics/data loggers.
- h. During an event the Technical Director has the right to ask a team to substitute their ECU or external module with the sample received from the Manufacturer. The change has to be done before Sunday warm up.
- i. No extra sensors may be added for control strategies except shift rod sensor, wheel speed sensors and lambda sensors. Any of these sensors must be included in the Kit ECU and Harness package if required for strategies (including closed loop lambda).
- j. Other additional electronic hardware equipment not on the original homologated motorcycle cannot be added with the exceptions noted below.
- k. Resistors/load may be added to replace the parts of the electrical system that have been removed (including lights and lambda sensors), to prevent ECU errors.
- l. An ABS replacement/bypass may be fitted and or the ABS unit may be dismantled to leave just its ECU.
- m. The data logging system is free. The data logger may not act to control any strategy or setting in the ECU - except to replicate the original dashboards signals if the original dashboard is removed. The logger may not automate these setting changes.
- n. The addition of a device for infrared (IR) transmission of a signal between the racing rider and his team, used exclusively for lap timing.
- o. The addition of a GPS unit for lap timing/scoring purposes is allowed.
- p. Telemetry is not allowed.

- q. Harness:
 - a. The main wiring harness may be replaced by the kit wire harness as supplied for the Kit ECU model, produced and/or approved by the manufacturer of the motorcycle. Other main wiring harness are also allowed to fit other Kit ECUs (refer to Art. 4.6.9.1 a) iv)).
 - b. The Kit wiring harness may incorporate the data logging harness.
 - c. The key/ignition lock may be relocated, replaced or removed.
 - d. Cutting of the original main wiring harness is allowed.
- r. External modules may not alter any sensor signal relating to the ride by wire system or control/actuate any part of the machine excepting the ignition coils and fuel injectors.

No external module may add traction control strategies unless originally fitted to the homologated machine. Downshift blip is only allowed when controlled by the approved "Superstock Kit" ECU, external downshift blip modules are NOT allowed.

- s. The original speedometer and tachometer may be altered or replaced (see also 4.6.11) The dashboard is free, however it may only replace the functions of the standard dashboard (including switch logic and display) and may not perform any other logic function on the bike unless included in the "Superstock Kit". If essential for the operation of the electronics it must be included in the "Superstock Kit". It may also contain the datalogger. There must remain a working Tachometer display.
- t. Spark plugs may be replaced.
- u. Battery is free.

4.6.9.2 Generator, alternator, electric starter

- a. The generator (ACG) must be the originally fitted and homologated part with no modification allowed.
- b. The stator must be fitted in its original position and without offsetting.
- c. The electric starter must operate normally and always be able to start the engine during the event.
- d. During final technical inspections the starter must crank the engine at a suitable speed for starting for a minimum of 2 seconds without the use a boost battery. No boost battery may be connected to the machine after the end of the session.

4.6.10 Main frame

During the entire duration of the event, each rider can only use one (1) complete motorcycle, as presented for Technical Control, with the frame clearly identified with a seal. In case the frame will need to be replaced, **only if the frame is damaged**, the rider or the team must request the use of a spare frame to the Technical Director. **Other circumstances may be taken into account by Race Direction.**

The pre-assembled spare part frame must be presented to the Technical Director for the permission of rebuilding. The pre-assembly shall be strictly limited to:

- Main frame
- Bearings (steering pipe, swing arm , etc)
- Swing arm
- Rear suspension linkage and shock absorber
- Upper and lower clamps (triple clamp, fork bridges)
- Wiring harness

The spare frame will not be allowed in the pit box before the rider or the team has received authorization from the Technical Director.

The rebuilt motorcycle must be inspected before its use by the technical stewards for safety checks and a new seal will be placed on the motorcycle frame.

No other spare machine may be at the track. If found penalties will be applied. For the remainder of the event the machine will be impounded and no part of that machine may be used for spare parts.

4.6.10.1 Frame body and Rear sub frame

- a. The frame must remain as originally produced by the manufacturer for the homologated motorcycle.
- b. Holes may be drilled on the frame only to fix approved components (i.e. fairing brackets, steering damper mount, sensors).
- c. The sides of the frame-body may be covered by a protective part made of a composite material. These protectors must fit the form of the frame, but they must leave an empty place to add the technical control sticker close to the right side of the pivot frame.
- d. Crash protectors may be fitted to the frame, using existing points (max length: 50 mm), or pressed into the ends of the wheel axles (max length: 30 mm). Without exception, the wheel axles cannot be modified.
- e. Nothing else may be added or removed from the frame body.
- f. All motorcycles must display a vehicle identification number punched on the frame body (chassis number).
- g. Engine mounting brackets or plates must remain as originally produced by the manufacturer for the homologated motorcycle.
- h. Front sub frame / fairing mount may be changed or altered but the use of titanium and carbon (or similar composite materials) is forbidden.
- i. Rear sub frame may be changed or altered, but the type of material must remain as homologated, or material of a higher specific weight.
- j. Additional seat brackets may be added, non-stressed protruding brackets may be removed if they do not affect the safety of the construction or assembly. Bolt-on accessories to the rear sub-frame may be removed.

- k. The paint scheme is not restricted but polishing the frame body or sub frame is not allowed.

4.6.10.2 Suspension - General

- a. Electronic Suspension:
 - i. No aftermarket or prototype electronically-controlled suspensions may be used. Electronically-controlled suspension may only be used if already present on the production model of the homologated motorcycle.
 - ii. The electronically-controlled valves must remain as homologated. The shims, spacers and fork/shock springs not connected with these valves can be changed.
 - iii. The ECU for the electronic suspension must remain as homologated and cannot receive any motorcycle track position or sector information; the suspension cannot be adjusted relative to track position.
 - iv. The electronic interface between the rider and the suspension must remain as on the homologated motorcycle. It is allowed to remove or disable this rider interface.
 - v. The original suspension system must work safely in the event of an electronic failure.
 - vi. Electro-magnetic fluid systems which change the viscosity of the suspension fluid(s) during operation are not permitted.
- b. Electronic controlled steering damper cannot be used if not installed on the homologated model for road use. However, it must be completely standard (any mechanical or electronic part must remain as homologated).

4.6.10.3 Front Forks

- a. Forks (stanchions, stem, wheel spindle, upper and lower crown, etc.) must remain as originally produced by the manufacturer for the homologated motorcycle.
- b. The upper and lower fork clamps (triple clamp, fork bridges) must remain as originally produced by the manufacturer on the homologated motorcycle.
- c. Steering stem pivot position must remain in the homologated position (as supplied on the production bike). If the standard bike has inserts then the orientation/position of the original insert may be changed but the insert cannot be replaced or modified.
- d. A steering damper may be added or replaced with an after-market damper.
- e. The steering damper cannot act as a steering lock limiting device.
- f. Fork caps on the mechanical forks may only be modified or replaced to allow external adjustment. (This does not include the mechanical fork leg that is part of the homologated electronic fork set)
- g. Dust seals may be modified, changed or removed if the fork remains totally oil-sealed
- h. Mechanical forks: Original internal parts of the homologated forks may be modified or changed. After market damper kits or valves may be installed. The original surface finish of the fork tubes (stanchions, fork pipes) may be changed. Additional surface treatments are allowed.
- i. Electronic forks: The electronic front suspension may be replaced with a mechanical system from a similar homologated model from the same manufacturer.

- j. Electronic forks may have their complete internal parts (including all electronic control) replaced with a conventional damping system and it will be considered as a mechanical fork.

4.6.10.4 Rear fork (Swing arm)

- a. The rear fork must remain as originally produced by the manufacturer for the homologated motorcycle.
- b. Rear fork pivot bolt must remain as originally produced by the manufacturer for the homologated motorcycle.
- c. Rear swingarm pivot position must remain in the homologated position (as supplied on the production bike). If the standard bike has inserts then the orientation/position of the original insert may be changed but the insert cannot be replaced or modified.
- d. A solid protective cover (shark fin) shall be fixed to the swing-arm, and must always cover the opening between the lower chain run, swing-arm and the rear wheel sprocket, irrespective of the position of the rear wheel.
- e. Rear wheel stand brackets may be added to the rear fork by welding or by bolts. Brackets must have rounded edges (with a large radius). Fastening screws must be recessed. An anchorage system or point(s) to keep the original rear brake caliper in place may be added to the rear swing-arm.
- f. The sides of the swing-arm may be protected by a thin vinyl cover only, no composite or structural covers are allowed.

4.6.10.5 Rear suspension unit

- a. Rear suspension unit (shock absorber) may be modified or replaced, but the original attachments to the frame and rear fork (swing arm) (or linkage) must be as homologated.
- b. All the rear suspension linkage parts must remain as originally produced by the manufacturer for the homologated motorcycle.
- c. Removable top shock mounts must be the originally fitted and homologated part with no modification allowed. A nut may be made captive on the top shock mounts and shim spacers may be fitted behind it to adjust ride height.
- d. Mechanical suspension: Rear suspension unit and spring may be changed.
- e. Electronic suspension: If the standard system has no facility for ride height adjustment the standard shock may be modified to allow shock length change if no hydraulic parts are modified. The electronic shock absorber can be replaced with a mechanical one.

4.6.10.6 Wheels

- a. Wheels must remain as originally produced by the manufacturer for the homologated motorcycle.
- b. The wheels may be overpainted but the original finish cannot be removed.
- c. A non-slip coating / treatment may be applied to the bead area of the rim.

- d. If the original design includes a cushion drive for the rear wheel, it must remain as originally produced for the homologated motorcycle.
- e. Wheel axles must remain as homologated, wheel spacers may be modified or replaced.
- f. Bearing spacers must remain as homologated.
- g. Wheel balance weights may be discarded, changed or added to.
- h. Aluminium or steel inflation valves are compulsory. Angled valves are recommended.

4.6.10.7 Brakes

- a. Brake discs may be replaced by aftermarket discs which comply with following requirements:
 - i. Brake discs must retain the same material as the homologated disc and carrier or Steel (max. carbon content 2.1 wt%).
 - ii. Non-floating or single piece discs may be replaced with floating discs. The disc carrier must be the same material as the homologated carrier, steel or aluminum.
 - iii. The outside and inner diameters of the brake disc must not be larger than the ones on the homologated disc.
 - iv. The thickness of the brake disc may be increased but the disc must fit into the homologated brake caliper without any modification. The number of floaters is free.
 - v. The fixing of the carrier on the wheel must remain the same as on the homologated disc.
- b. The front and rear brake caliper (mount, carrier, hanger) must remain as originally produced by the manufacturer for the homologated motorcycle.
- c. In order to reduce the transfer of heat to the hydraulic fluid it is permitted to add metallic shims to the calipers, between the pads and the calipers, and/or to replace light alloy pistons with steel pistons made by the same manufacturer of the caliper.
- d. The rear brake caliper bracket may be mounted fixed on the swing-arm, but the bracket must maintain the same mounting (fixing) points for the caliper as used on the homologated motorcycle.
- e. The swing-arm may be modified for this reason to aid the location of the rear brake caliper bracket, by welding, drilling or by using a helicoil.
- f. The front and rear master cylinder may be changed with aftermarket products. Front and rear brake fluid reservoirs may be changed with aftermarket products.
- g. An additional rear brake master cylinder can be installed on the left handlebar.
- h. Front and rear hydraulic brake lines may be changed.
- i. The split of the front brake lines for both front brake calipers must be made above the lower fork bridge (lower triple clamp).
- j. "Quick" (or "dry-brake") connectors in the brake lines are allowed.

- k. Front and rear brake pads may be changed. Brake pad locking pins may be modified for quick change type.
- l. Additional air scoops or ducts are not allowed.
- m. The Antilock Brake System (ABS) may be used only if installed in the homologated model for road use. However, it must be completely standard (any mechanical or electronic part must remain as homologated, brake discs and master cylinder levers excluded), and only the software of the ABS may be modified.
- n. The Antilock Brake system (ABS) can be disconnected and its ECU can be dismantled. The ABS rotor wheel can be deleted, modified or replaced.
- o. Motorcycles must be equipped with brake lever protection, intended to protect the handlebar brake lever from being accidentally activated in case of collision with another motorcycle. Composite guards are not permitted. FIM approved guards will be permitted without regard of the material. The Technical Director has the right to refuse any guard not satisfying this safety purpose

4.6.10.8 Handlebars and hand Controls

- a. Handlebars may be replaced.
- b. Handlebars and hand controls may be relocated.
- c. Throttle controls must be self closing when not held by the hand.
- d. Throttle assembly and associated cables may be modified or replaced but the connection to the throttle body and to the throttle controls must remain as on the homologated motorcycle. Cable operated throttles (grip assembly) must be equipped with both an opening and a closing cable including when actuating a remote drive by wire grip/demand sensor.
- e. Clutch and brake lever may be replaced with an after-market model. An adjuster to the brake lever is allowed.
- f. Switches may be changed but the electric starter switch and engine stop switch must be located on the handlebars.
- g. Motorcycles must be equipped with a functional ignition kill switch or button mounted on the right hand handlebar (within reach of the hand while on the hand grips) that is capable of stopping a running engine. The button or switch must be RED.
- h. A thumb operated rear brake solution is allowed.

4.6.10.9 Foot rest / Foot controls

- a. Foot rests, hangers/brackets and hardware may be replaced and relocated but the hangers/brackets must be mounted to their original frame mounting points.
- b. Foot controls; gear shift and rear brake must remain operated manually by foot.
- c. Foot rests may be rigidly mounted or a folding type which must incorporate a device to return them to the normal position.
- d. The end of the foot rest must have at least an 8 mm solid spherical radius.

- e. Non folding footrests must have an end (plug) which is permanently fixed, made of aluminium, plastic, Teflon® or an equivalent type material (minimum radius 8mm). The plug surface must be designed to reach the widest possible area. The Technical Director has the right to refuse any plug not satisfying this safety aim.

4.6.10.10 Fuel tank

- a. Fuel tank must remain as originally produced by the manufacturer for the homologated motorcycle.
- b. All fuel tanks must be completely filled with fire retardant material (open-celled mesh, i.e. Explosafe®).
- c. Fuel tanks with tank breather pipes must be fitted with non-return valves that discharge into a catch tank with a minimum volume of 250cc made of a suitable material.
- d. Fuel cap must be changed for a "screw type" cap to prevent accidental opening at any time. Fuel cap when closed must be leak proof.
- e. A rider spacer/pad may be fitted to the rear of the tank with nonpermanent adhesive. It may be constructed of foam padding or composite material.
- f. The tank may not have a cover fitted over it unless the homologated machine also features a full cover.
- g. The sides of the fuel tank may be protected with a cover made of a composite material. These covers must fit the shape of the fuel tank.
- h. Fuel tank cannot have heat reflective material attached to its bottom surface.

4.6.10.11 Fairing / Body work

- a. Fairing and bodywork may be replaced with exact cosmetic duplicates of the original parts, but must appear to be as originally produced by the manufacturer for the homologated motorcycle, with slight differences due to the racing use (different pieces mix, fixing points, fairing bottom, etc). The material may be changed. The use of carbon fibre or carbon composite materials is not allowed. Specific reinforcements in Kevlar® or carbon are allowed locally around holes and stressed areas. Headlights must be included even when considered external.
- b. For all bodywork paint and decal design is free.
- c. Overall size and dimensions must be the same as the original part, with a tolerance of +/-10mm, respecting the design and features of the homologated fairing as far as possible. The overall width of the frontal area may be +10mm maximum. The decision of the Technical Director is final.
- d. Wind screen may be replaced with an aftermarket product. The height of the windscreen is free, within a tolerance of +/- 15 mm referred to the vertical distance from/to the upper fork bridge. The screen must conform to the same profile from the front as the original. From a top view the length of the windscreen may be shortened by 25mm to allow clearance for the rider. The edge of the screen must have no sharp edges.

- e. The original combination instrument/fairing brackets may be replaced, but the use of titanium and carbon (or similar composite materials) is forbidden. All other fairing brackets may be altered or replaced.
- f. The ram-air intake must maintain the originally homologated shape and dimensions.
- g. The original air ducts running between the fairing and the air box may be altered or replaced. Carbon fibre composites and other exotic materials are forbidden. Particle grills or “wire-meshes” originally installed in the openings for the air ducts may be taken away.
- h. The lower fairing must to be constructed to hold, in case of an engine breakdown minimum 6 litres. The lower edge of all the openings in the fairing must be positioned at least 70 mm above the bottom of the fairing.
- i. There may be no exit air vents in the front half of the lower fairing below a line 40mm below line between the wheel axles of the machine. The Technical Director may give permission for the lower fairing to have additional vents added if vents have been filled to meet the these and the oil containment requirements.
Any added vents will not allow the exit of air in the front half of the fairing lower if they are behind a water or oil radiator.
- j. Exceptions may be made to 4.6.10.11.i with the sole agreement of the Technical Director if a manufacturer produced and FIM approved close fitting, oil containing engine shroud is fitted in addition to the bellypan. In this case OEM shaped air vents will be allowed in the front lower half of the fairing.
- k. Any vents in the fairing lower must have their inner surface finish in-line with their outer surface or overlap to reduce the risk of liquid spraying from the machine.
- l. The upper edge of the rear transverse wall of the lower fairing must be at least 70 mm above the bottom. The angle between this wall and the floor must be $\leq 90^\circ$.
- m. Original openings for cooling in the lateral fairing/bodywork sections may be partially closed only to accommodate sponsors' logos/lettering. Such modification shall be made using wire mesh or perforated plate. The material is free but the distance between all opening centres, circle centres and their diameters must be constant. Holes or perforations must have an open area ratio $> 60\%$.
- n. Motorcycles may be equipped with a radiator shroud (inner ducts) to improve the air stream towards the radiator but the appearance of the front, the rear and the profile of the motorcycle must not be changed.
- o. The lower fairing may incorporate a single opening of $\varnothing 25$ mm diameter in the front lower area. This hole must remain sealed in dry conditions and must be only opened in wet race conditions.
- p. Front mudguards may be replaced with a cosmetic duplicate of the original parts and may be spaced upward for increased tyre clearance.
- q. Rear mudguard fixed on the swing arm may be modified, changed or removed. The chain guard may be removed as long as it is not incorporated in the rear fender.

4.6.10.12 Seat

- a. Seat, seat base and associated bodywork may be replaced. The appearance from front, rear and profile must conform to the homologated shape

- b. The top portion of the rear bodywork around the seat may be modified to a solo seat.
- c. The homologated seat locking system (with plates, pins, rubber pads etc.) may be removed.
- d. Same materials as fairings must be used (article 4.6.10.11.a).
- e. All exposed edges must be rounded.

4.6.10.13 Fasteners

- a. Standard fasteners may be replaced with fasteners of any material and design but titanium fasteners cannot be used. The strength and design must be equal to or exceed the strength of the standard fastener.
- b. Fasteners may be drilled for safety wire, but intentional weight-reduction modifications are not allowed.
- c. Thread repair using inserts of different material such as helicoils and timeserts is allowed.
- d. Fairing / bodywork fasteners may be replaced with the quick disconnect type.
- e. Aluminium fasteners may only be used in non-structural locations.

4.6.10.14 Rear Safety Light

All motorcycles must have a functioning red light mounted at the rear of the machine, to be used in rain or low visibility conditions. The team must ensure that the light is switched on any time the motorcycle is on the track or being ridden in the pit-line whenever a rain tyre is fitted on the motorcycle. All lights must comply with the following:

- a. Lighting direction must be parallel to the machine centre line (motorcycle running direction), and be clearly visible from the rear at least 15 degrees to both left and right sides of the machine centre line.
- b. The rear light must be mounted near the end of the seat/rear bodywork and approximately on the machine centre line, in a position approved by the FIM CVEV Technical Director. In case of dispute over the mounting position or visibility, the decision of the Technical Director will be final.
- c. Power output/luminosity equivalent to approximately: 10 – 15 (incandescent), 0.6 – 1,8 W (LED).
- d. The output must be continuous - no flashing safety light whilst on track, flashing is allowed in the pit lane when pit limiter is active.
- e. Safety light power supply may be separated from the motorcycle.
- f. The Technical Director has the right to refuse any light system not satisfying this safety purpose.

4.6.11 The following items MAY be altered or replaced from those fitted to the homologated motorcycle.

- a. Any type of lubrication, brake or suspension fluid may be used.
- b. Gaskets and gasket materials.
- c. Instruments, instrument bracket(s) and associated cables.
- d. Painted external surface finishes and decals.
- e. Material for brackets connecting non original parts (fairing, exhaust, instruments, etc) to the frame (or engine) cannot be made from titanium or fibre reinforced composites excepting the exhaust silencer hanger that may be in carbon.
- f. Protective covers for the frame, chain, footrests, etc. may be made in other materials like fibre composite material if these parts do not replace original parts mounted on the homologated model.

4.6.12 The following items MAY BE removed

- a. Emission control items (anti-pollution) in or around the air box and engine (O2 sensors, air injection devices).
- b. Bolt-on accessories on a rear sub frame.

4.6.13 The following items MUST BE removed

- a. Headlamp, rear lamp and turn signal indicators (when not incorporated in the fairing). Openings must be covered by suitable materials.
- b. Rear-view mirrors.
- c. Horn.
- d. License plate bracket.
- e. Toolkit.
- f. Helmet hooks and luggage carrier hooks
- g. Passenger foot rests.
- h. Passenger grab rails.
- i. Safety bars, centre and side stands must be removed (fixed brackets must remain).
- j. Catalytic convertors.

4.6.14 General Items

4.6.14.1 Materials

The use of titanium in the construction of the frame, the front forks, the handlebars, the swing-arms, the swing-arm spindles and the wheel spindles is forbidden. For wheel

spindles, the use of light alloys is also forbidden. The use of titanium alloy nuts and bolts isn't allowed in this class.

- a. Titanium test to be performed on the track: magnetic test (titanium is not magnetic).
- b. The 3 % nitric acid test (titanium does not react. If metal is steel, the drop will leave a black spot).
- c. Specific weight of titanium alloys is between 4.5 and 5.0 kg/dm³ vs, over 7.48 kg/dm³ of steel and can be ascertained by weighing the part and measuring its volume in a calibrated glass filled with water (intake valve, rocker, connecting rod, etc.)
- d. In case of doubt, the test must take place at a Material Testing Laboratory.

4.6.14.2 Handlebars and Control Levers

Exposed handlebar ends must be plugged with a solid material or rubber covered.

The minimum angle of rotation of the steering on each side of the centre line or mid position must be of 15°.

Whatever the position of the handlebars, the front wheel, tyre and the mudguard must maintain a minimum gap of 10 mm.

Solid stops, (other than steering dampers) must be fitted to ensure a minimum clearance of 30 mm between the handlebar with levers and the tank, frame or other bodywork when on full lock to prevent trapping the rider's fingers.

Repair by welding of light alloy handlebars is prohibited.

Composite handlebars are not allowed.

All handlebar levers (clutch, brake, etc.) must be ball ended (diameter of this ball to be at least 16 mm). This ball can also be flattened, but in any case the edges must be rounded (minimum thickness of this flattened part 14 mm). These ends must be permanently fixed and form an integral part of the lever.

Each control lever (hand and foot levers) must be mounted on an independent pivot.

The brake lever, if pivoted on the footrest axis, must work under all circumstances, such as the footrest being bent or deformed.

Modified rider controls will be considered for the mobility challenged subject to a report by the Medical director, the Technical Directors decision is final.

Clutch lever may have a guard fitted equivalent to a brake lever guard.

4.6.14.3 Compulsory safety Items

- a. All drain plugs must be lock wired (safety wired). External oil filter(s), screws and bolts that enter an oil cavity must be safety wired (i.e. on crankcases). The oil filter may optionally have a secondary retention mechanism.

- b. Where breather or overflow pipes are fitted they must discharge via existing outlets. The original closed system must be retained: no direct atmospheric emission is permitted.
- c. Motorcycles must be equipped with a red light on the instrument panel that will illuminate in the event of oil pressure drop.

4.6.14.4 Tyres

Tyres may be replaced from those fitted to the homologated motorcycle.

Only tyres distributed by the Official supplier at the event are authorized.

The tread pattern must be made exclusively by the manufacturer when producing the tyre.

4.6.14.5 The use of tyre warmers is allowed.

4.6.14.6 Use of tyres

The competitors shall only use tyres distributed by the Official Supplier during the event.

For each event, all tyres must be made of the same quality and shall be strictly identical.

During qualifying practices and race(s), rear tyres may be required to be marked with tyre stickers (see Art. 4.6.7).

The Technical director may, at this discretion, require the exchange of one (1) or more competitors' tyres for a tyre sample under his control. The tyres exchanged remain under his/her control and he/she can exchange them for the ones of another competitor.

4.6.14.7 Ballast

The use of ballast is allowed to stay over the minimum weight limit. The use of ballast must be declared to the Technical Director at the preliminary checks.

The ballast must be made of solid metallic piece/s, firmly and securely connected, either through an adapter or directly to the main frame or engine, with a minimum of two (2) steel bolts (min. 8 mm diameter, 8.8 grade or over). Other equivalent technical solutions must be submitted to the Technical Director for his/her approval.

Fuel in the fuel tank can be used as ballast. Nevertheless, the verified weight may never fall below the required minimum weight.

4.6.14.8 Timekeeping instruments

Please refer to Appendix 9

4.6.14.9 Homologated Parts

Homologated parts are the OEM parts supplied fitted to the machine during manufacture and as delivered. Unless stated otherwise these parts may not be remade, refinished, treated, coated or modified in any way.

4.6.14.10 Wings and Aerodynamic Aids

Wings and other aerodynamic aids will only be considered legal if originally fitted to the homologated road specification machine in all of Europe, Japan and North America.

For race use the wings must follow the dimensions and profiles of the homologated shapes exactly (+/- 2 mm). The leading edges (including end plates) must have a minimum circumference of 3 mm. all wings must have a rounded end (8 mm radius) or be enclosed/integrated into the fairing.

Alternatively the originally fitted and homologated wings may be used from the street bike without modification except to their fairing mounting.

The position of the wings must be +/- 5 mm, angle of attack +/- 2°.

4.6.15 Rider's Safety Equipment

Refer to [Appendix 11](#) ~~and 12~~

4.6.16 Procedure for Technical Control

Refer to [Appendix 12](#)

Appendix 7

5.6 EUROPEAN TALENT CUP TECHNICAL SPECIFICATIONS

The following rules are intended to permit limited changes to the homologated motorcycle in the interests of safety and improved competition.

EVERYTHING THAT IS NOT AUTHORISED AND PRESCRIBED IN THIS RULE IS STRICTLY FORBIDDEN

If a change to a part or system is not specifically allowed in any of the following articles, then it is forbidden.

The only model homologated is Honda NSF 250 R (Type MR03). All machines must be normally aspirated. All motorcycles must comply in every respect with all the requirements for road racing as specified in these Technical Regulations, unless they are already equipped as such on the homologated model.

The appearance from both front, rear and the profile of the motorcycles must (except when otherwise stated) conform to the homologated shape (as originally produced by the manufacturer). The appearance of the exhaust system is excluded from this rule.

5.6.1 Motorcycle specifications

All parts and systems not specifically mentioned in the following articles must remain as originally produced by the manufacturer for the homologated motorcycle

5.6.2 Displacement capacities

The following engine configurations comprise this class:

Honda NSF 250 R 4-stroke 1 cylinder

The displacement capacity, bore and stroke (new), must remain at the homologated size.

5.6.3 Minimum Weights

Refer also to [Appendix 12](#).

Minimum total weight of Motorcycle + Rider: 145 kg.

A limit to the amount of ballast that may be fixed to the machines of the lightest riders will be imposed: the minimum total weight will not be applied if the motorcycle's weight is 96 kg or more.

At any time of the event, the weight of the whole machine (including the tank and its contents) and rider, must not be lower than the minimum weight.

There is no tolerance on this minimum weight.

During the final technical inspection at the end of the race, the selected motorcycles and riders will be weighed in the condition they finished the race, and the established weight limit must be met in this condition. Nothing may be added to the motorcycle. This includes all fluids.

During the practice and qualifying sessions, riders may be asked to submit their motorcycle to a weight control. In all cases the rider must comply with this request.

The use of ballast is allowed to stay over the minimum weight limit and may be required due to the handicap system. The use of ballast and weight handicap must be declared to the Technical Director at the preliminary checks.

5.6.4 Numbers and number plates

The background colours and figures (numbers) for this class are white background with black numbers:

The sizes for all the front numbers are:

| | |
|-------------------------------|--------|
| Minimum height: | 140 mm |
| Minimum width: | 80 mm |
| Minimum stroke: | 20 mm |
| Minimum space between numbers | 10 mm |

The size for all the side numbers is:

| | |
|-------------------------------|--------|
| Minimum height: | 120 mm |
| Minimum width: | 70 mm |
| Minimum stroke: | 25 mm |
| Minimum space between numbers | 10 mm |

The allocated number (& plate) for the rider must be affixed on the machine as follows:

- a) once on the front, either in the centre of the fairing or slightly off to one side. The number must be centred on the white background with no advertising within 25mm in all directions.
- b) once on each side of the motorcycle. Alternatively, once across the top of the rear seat section with the top of the number towards the rider. The rear and side numbers are optional. The preferred location for the numbers on each side of the motorcycle is on the lower rear portion of the main fairing near the bottom. The number must be centered on the white background.
- c) The numbers must use sufficiently legible fonts.
- d) The background colour must be clearly visible around all edges of the number (including outline). Reflective or mirror type numbers are not permitted.
- e) Numbers cannot overlap.
- f) No machine may enter the circuit if it does not meet the above regulations. If the rider does enter the circuit then no lap times will be recorded and Race Direction will at their discretion black flag the rider.

In case of a dispute concerning the legibility of numbers, the decision of the Technical Director will be final.

5.6.5 Fuel

Refer to **Appendix 10**

5.6.6 Tyres

Only tyres from the official tyre supplier may be used in this class and each team must sign a contract.

The tyre specifications available at each event will be determined by the Championship Promoter. Only homologated tyres in each event are permitted.

The maximum number of rear slick tyres allowed to use during the qualifying practices are TWO (2). Only the rear slick tyres need to be marked with a tyre sticker.

A maximum of ONE (1) rear “dry” tyre per race may be used. Only the race rear “dry” tyres shall be marked with a code differentiable qualifying tyres.

The rain tyres will not need to be marked with a tyre sticker and will not be considered in the total number of tyres available for use.

During the preliminary technical inspection, the adhesive stickers used for marking the tyres will be delivered to the teams. Each team will be responsible of marking their tyres.

The Technical Stewards and /or the official tyre supplier may perform random controls during the qualifying practices and races. If the riders are shown a red flag during the practice or the race/s, the Permanent Race Direction is allowed to authorize the use of a supplementary tyre. All checked tyres must be easily identifiable with a colour marking or a numerical system. **The technical director and/or his/her crew has the right to ask to the team in any moment, to show all their tyres used during the event.**

In case of a technical problem, the Technical Director will take a decision about the problem.

5.6.7 Engine

- a. At any time, the Technical Director, under the supervision of Race Direction, may request a team that the engine used during a Qualifying Practice (QP) to be sealed and checked in a posterior inspection. This request must be submitted at any moment during the event and the team has the right to work in the engine maintenance until two (2) hours after this notification. This maintenance must be done with a technical steward present. At the end of this maintenance, the engine will be sealed.

5.6.7.1 Fuel Injection System

- a. The original homologated fuel injection system must be used without any modification. The nuts and washers that fix the throttle body to the cylinder head are excluded from this rule.
- b. The fuel injectors must be stock and unaltered from the original specification and manufacturer.
- c. Air Funnels must remain as originally produced by the manufacturer for the homologated motorcycle.

- d. Butterfly valves cannot be changed or modified.
- e. Air and air/fuel mixture must go to the combustion chamber exclusively through the throttle body.
- f. Electronically controlled throttle valves, known as 'ride-by-wire', cannot be used.

5.6.7.2 Cylinder Head

- a. Must be the originally fitted and homologated part with no modification allowed.
- b. The gaskets may be changed.
- c. The valves, valve seats, guides, springs, tappets, oil seals, shims, cotter valve, rocker arms, spring base and spring retainers must be as originally produced and in the original position as supplied by the manufacturer of the homologated motorcycle.
- d. Only normal maintenance interventions as prescribed by the Manufacturer in the service manual of the motorcycle are authorized.
- e. Valve spring shims are not allowed.

5.6.7.3 Camshafts

- a. Must be the originally fitted and homologated part with no modification allowed.

5.6.7.4 Cam sprockets

- a. Must be the originally fitted and homologated part with no modification allowed.
- b. The cam chain and tensioner must remain as homologated.

5.6.7.5 Cylinder

Must be the originally fitted and homologated part with no modification except its height. The total height (included the cylinder and gasket) must be at least 0,2 mm. more than the standard motorcycle cylinder height.

5.6.7.6 Pistons

Must be the originally fitted and homologated part with no modification allowed.

5.6.7.7 Piston rings

Must be the originally fitted and homologated part with no modification allowed.

5.6.7.8 Piston pin and Clips

Must be the originally fitted and homologated part with no modification allowed.

5.6.7.9 Connecting rod

Must be the originally fitted and homologated part with no modification allowed.

5.6.7.10 Crankshaft

Must be the originally fitted and homologated part with no modification allowed.

5.6.7.11 Crankcase / Gearbox housing

- a. Crankcases must remain as homologated. No modifications are allowed (including painting, polishing and lightening).
- b. It is not allowed to add a pump used to create a vacuum in the crankcase.

5.6.7.11.1 Lateral covers and protection

- a. Lateral (side) covers may not be altered, modified or replaced.
- b. All lateral covers/engine cases containing oil and which could be in contact with the ground during a crash, could be protected by a second cover made from metal, such as aluminium alloy, stainless steel or steel, composite covers are not permitted.
- c. The secondary cover must cover a minimum of 1/3 of the original cover. It must have no sharp edges to damage the track surface.
- d. Plates or crash bars made from aluminium or steel also are permitted in addition to these covers. All of these devices must be designed to be resistant against sudden shocks, abrasions and crash damage.
- e. FIM approved covers will be permitted without regard of the material or its dimensions.
- f. These covers must be fixed properly and securely with a minimum of three (3) case cover screws that also mount the original covers/engine cases to the crankcases.
- g. Oil containing engine covers must be secured with steel bolts.
- h. The Technical Director has the right to refuse any cover not satisfying this safety purpose.

5.6.7.12 Transmission / Gearbox

- a. Must be the originally fitted and homologated part with no modification allowed.
- b. Quick-shift systems are allowed (including wire and potentiometer).
- c. Countershaft sprocket, rear wheel sprocket, rear sprocket carrier hub, chain pitch and size may be changed.

5.6.7.13 Clutch

- a. Must be the originally fitted and homologated part with no modification allowed.
- b. Friction and drive discs may be changed, but their number must remain as original.
- c. Helical clutch springs may be changed, but only the non-helical clutch springs can be eliminated.

5.6.7.14 Oil pumps and Oil lines

- a. Must be the originally fitted and homologated part with no modification allowed.

5.6.7.15 Radiator and cooling system

- a. The only liquid engine coolants permitted is water.

- b. The water radiator must be the originally fitted and homologated part with no modification allowed.
- c. Protective meshes may be added in front of the water radiator.
- d. The cooling system hoses and catch tanks may be changed.
- e. Radiator cap is free.

5.6.7.16 Air box

- a. The air box (and its included ram-air intake) must remain as originally produced by the manufacturer on the homologated motorcycle.
- b. The air filter element may be modified or replaced but must be mounted in the original position. This element cannot be used to modify the air flow inside/outside the airbox.
- c. The air box drains must be sealed.
- d. All motorcycles must have a closed breather system. All the oil breather lines must be connected, may pass through an oil catch tank and must exclusively discharge in the airbox.
- e. No heat protection may be attached to the airbox.

5.6.7.17 Fuel supply

- a. Fuel pump and fuel pressure regulator must remain as homologated.
- b. The fuel pressure must be as homologated.
- c. Fuel lines from the fuel tank to the delivery pipe assembly (excluded) may be replaced and must be located in such a way that they are protected from crash damage.
- d. Quick connectors or dry break connectors may be used.
- e. Fuel vent lines may be replaced.
- f. Fuel filters may be added.

5.6.7.18 Exhaust system

- a. Exhaust pipes and silencers may be modified or changed.
- b. The number of the final exhaust silencers must remain as homologated. The exhaust pipe outlet must be on the same side of the homologated model.
- c. For safety reasons, the exposed edges of the exhaust pipe outlet must be rounded to avoid any sharp edges.
- d. Wrapping of exhaust systems is not allowed except in the area of the rider's foot or an area in contact with the fairing for protection from heat.
- e. Coating of exhaust systems is not allowed.
- f. The noise limit will be 115 dB/A (with a 3 dB/A tolerance after the race only)

5.6.7.19 Sound level control

Refer to [Appendix 12](#).

5.6.7.19.1 Sound limits in force:

Noise will be controlled at: Max. 115 dB/A measured in a static test at 5.500rpm.

5.6.7.19.2 Noise control after the competition

In a competition which requires a final examination of machines before the results are announced, this examination can include a noise control measurement of at least the first three machines listed in the final classification. At this final test, there will be a 3 dB/A tolerance.

5.6.8 Electrics and Electronics

5.6.8.1 Ignition / Engine Control System (ECU)

- a. Central unit (ECU) must be the originally fitted and homologated part with no modification allowed.
- b. It isn't allowed to add injection modules that modify the inputs/outputs of the Central unit (ECU).
- c. The software used to modify the ECU must be the originally produced by the manufacturer for the homologated motorcycle.
- d. The parameters that the software itself provides for adjustment, cannot be extended and/or exceeded under any circumstances.
- e. The Technical Director could, at its discretion, download and analyze the files and maps of the Central Unit (ECU).
- f. Central unit (ECU) may be relocated.
- g. During an event the Technical Director has the right to ask a team to substitute their ECU with the sample received from the Manufacturer. The change has to be done before Sunday warm up.
- h. The data logging system is free. The data logger may not act to control any strategy or setting in the ECU. The logger may not automate these setting changes. The maximum number of inputs by external sensors allowed are:
 - 1) Position and speed by GPS
 - 2) Engine temperature (water)
 - 3) Lambda signal
 - 4) TPS signal
 - 5) Engine RPM
 - 6) Rear Wheel speed
 - 7) Front Wheel speed
 - 8) Front brake pressure
 - 9) Rear brake pressure
 - 10) Front fork position
 - 11) Rear damper position
- i. The addition of a device for infrared (IR) transmission of a signal between the racing rider and his team, used exclusively for lap timing, is allowed.

- j. The addition of a GPS unit for lap timing/scoring purposes is allowed.
- k. Telemetry is not allowed.
- l. Harness must be the originally fitted and homologated part with no modification allowed except:
 - a) Modifications are only allowed for data download proposal (Datalogger).
 - b) These modifications must be authorized by the Technical Director.
 - c) Map Selector and Pit-limiter switches are considered homologated parts of the harness.
- m. The original temp meter and tachometer may be altered, replaced or eliminated. It can be replaced only by one of the authorized dashboards:
 - **2D MiniDash - DI-KIT_MID12-000**
 - **AiM GS-Dash – X55GSDASH0**
 - **AiM MXm – X87MXM0000**
 - **Starlane Corsaro-R – CORS**
 - **Starlane DaVinci-II r – CDAV2R**
 - **GET D30-Evo – GK-D30EVO1-0001**

It can be added a display/s for lap-timing and gear selection purposes only.

- n. The standard sensors of the ECU, cannot be changed, modified or eliminated.
- o. Spark plug may be replaced.
- p. A battery can be installed and connected with the sole purpose of feeding the Lambda sensor and the data logging system.

5.6.8.2 Generator, alternator, electric starter

- a. The generator (ACG) must be the originally fitted and homologated part with no modification allowed.
- b. The stator must be fitted and connected to the wiring loom, in its original position and without offsetting.

5.6.9 Main frame

Note: please also refer to **Appendix 8**.

During the entire duration of the event, each rider can only use one (1) complete motorcycle, as presented for Technical Control, with the frame clearly identified with a seal. In case the frame will need to be replaced, **only if the frame is damaged**, the rider or the team must request the use of a spare frame to the Technical Director. **Other circumstances may be taken into account by Race Direction.**

The pre-assembled spare part frame must be presented to the Technical Director for the permission of rebuilding. The pre-assembly shall be strictly limited to:

- Main frame
- Bearings (steering pipe, swing arm , etc)
- Swing arm
- Rear suspension linkage and shock absorber

- Upper and lower clamps (triple clamp, fork bridges)
- Wiring harness

The spare frame will not be allowed in the pit box before the rider or the team has received authorization from the Technical Director.

The rebuilt motorcycle must be inspected before its use by the technical stewards for safety checks and a new seal will be placed on the motorcycle frame.

No other spare machine may be at the track. If found, penalties will be applied. For the remainder of the event the machine will be impounded and no part of that machine may be used for spare parts.

Once the starting procedure is initiated, it isn't possible to verify a second motorcycle, neither in case of detention by red flag. In case of events with two races, once the first race is finished, the Technical Director may allow the request for verification of a second motorcycle.

5.6.9.1 Frame body and Rear sub frame

- The frame must remain as originally produced by the manufacturer for the homologated motorcycle.
- Holes may be drilled (or welding may be added) on the frame only to fix approved components (i.e. fairing brackets, steering damper mount, sensors).
- The sides of the frame-body may be covered by a protective part made of a composite material. These protectors must fit the form of the frame, but they must leave an empty place to add the technical control sticker close to the right side of the pivot frame.
- Crash protectors may be fitted to the frame, using existing points (max length: 50 mm), or pressed into the ends of the wheel axles (max length: 30 mm).
- Nothing else may be added or removed from the frame body.
- All motorcycles should display a vehicle identification number (chassis number).
- Engine mounting brackets or plates must remain as originally produced by the manufacturer for the homologated motorcycle.
- Rear sub frame may be changed or altered, to allow different riders, but the type of material must remain as homologated, or material of a higher specific weight.
- Additional seat brackets may be added, non-stressed protruding brackets may be removed if they do not affect the safety of the construction or assembly. Bolt-on accessories to the rear sub-frame may be removed.
- The paint scheme is not restricted but polishing the frame body or sub frame is allowed with the sole aim of improving its aesthetics.

5.6.9.2 Front Forks

- Forks (stanchions, stem, wheel spindle, upper and lower crown, etc.) must remain as originally produced by the manufacturer for the homologated motorcycle.
- The upper and lower fork clamps (triple clamp, fork bridges) must remain as originally produced by the manufacturer on the homologated motorcycle, except:

1. The lower fork clamp can be modified to improve the steering stops. Check also [Appendix 8](#).
 2. The upper fork clamp can be drilled in order to screw a new brake fluid reservoir.
- c. Steering stem pivot position must remain in the homologated position (as supplied on the production bike).
 - d. The steering damper may be eliminated or replaced with an after-market damper.
 - e. The steering damper cannot act as a steering lock limiting device.
 - f. Fork caps cannot be modified or replaced.
 - g. Dust seals may be modified, changed or removed if the fork remains totally oil-sealed.
 - h. The springs of the homologated forks may be modified or changed. Any quantity and quality of oil can be used. The original surface finish of the fork tubes (stanchions, fork pipes) cannot be changed. Additional surface treatments are not allowed.
 - i. The inner parts of the cartridges can be modified or replaced. The external aspect cannot be modified, except adding holes, or enlarging existing holes. It's allowed to eliminate existing parts of the homologated cartridges, but those eliminated parts cannot be replaced with not original ones. In any case, these modifications must be based on a homologated cartridge.

5.6.9.3 Rear fork (Swingarm)

- a. The rear fork must remain as originally produced by the manufacturer for the homologated motorcycle. The paint scheme is not restricted but polishing the swingarm is allowed with the sole aim of improving its aesthetics.
- b. Rear fork pivot bolt must remain as originally produced by the manufacturer for the homologated motorcycle.
- c. Rear swingarm pivot position must remain as originally produced by the manufacturer for the homologated motorcycle.
- d. A solid protective cover (shark fin) shall be fixed to the swing-arm, and must always cover the opening between the lower chain run, swing-arm and the rear wheel sprocket, irrespective of the position of the rear wheel. The material of this cover is free.
- e. Rear wheel stand brackets may be added in the original position. Brackets must have rounded edges (with a large radius).
- f. The sides of the swing-arm may be protected by a thin vinyl cover only, no composite or structural covers are allowed.

5.6.9.4 Rear suspension unit

- a. Rear suspension unit (shock absorber) cannot be externally modified or replaced and the original attachments to the frame and rear fork (swing arm) (or linkage) must be as homologated.
- b. All the rear suspension linkage parts must remain as originally produced by the manufacturer for the homologated motorcycle.
- c. Rear suspension spring may be changed. Any quantity and quality of oil can be used.

- d. The inner valves and piston of the hydraulic components can be modified or replaced.
- e. The total length of the shock absorber must remain between the limits recommended by the manufacturer for the homologated motorcycle. **Please refer to diagram below:**

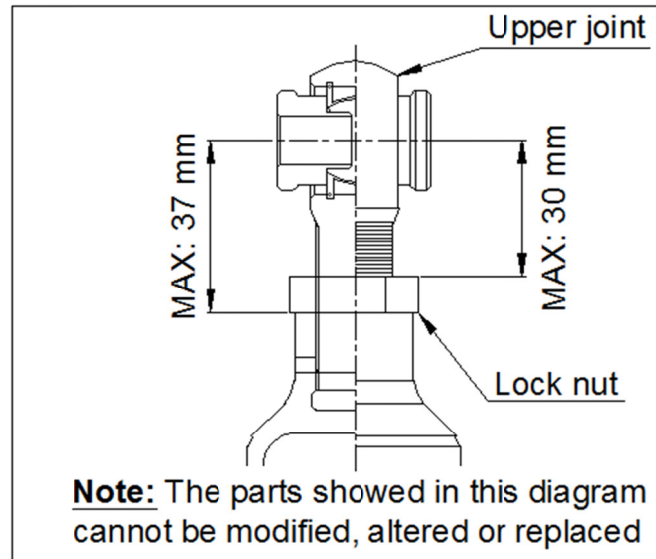

5.6.9.5 Wheels

- a. Wheels can be changed or modified, but the only material allowed is aluminium alloys.
- b. The only permitted wheel rim sizes are:
 - Front 2.50" x 17"
 - Rear 3.50" x 17"
- c. A non-slip coating / treatment may be applied to the bead area of the rim.
- d. Wheel axles, bearings and wheel spacers may be modified or replaced.
- e. The use of titanium and light alloys in the construction of the wheel axes is forbidden.
- f. Wheel balance weights may be discarded, changed or added to.
- g. Aluminium or steel inflation valves are compulsory. Angled valves are recommended.
- h. The use of any device on the wheel to adjust the tyre pressure whilst on track is prohibited.

5.6.9.6 Brakes

- a. Brake discs may be replaced by aftermarket discs which comply with following requirements:
 - i. Brake discs must retain the same material as the homologated disc and carrier or Steel (max. carbon content 2.1 wt%).
 - ii. The outside diameter of the front brake disc must be between 290 and 300 mm.

- iii. The thickness is limited to 5,5 mm.
- b. The **front brake** caliper (mount, carrier, hanger) can be changed or modified. Monobloc calipers are forbidden.
- c. The pistons of the front brake caliper are limited to 36 mm of diameter. The only material allowed for this part is aluminium.
- d. In order to reduce the transfer of heat to the hydraulic fluid it is permitted to add metallic shims to the calipers, between the pads and the calipers, and/or to replace light alloy pistons with steel pistons made by the same manufacturer of the caliper.
- e. The front and rear master cylinder may be changed with aftermarket products. Front and rear brake fluid reservoirs may be changed with aftermarket products.
- f. An additional rear brake master cylinder can be installed on the left handlebar.
- g. Front and rear hydraulic brake lines may be changed.
- h. "Quick" (or "dry-brake") connectors in the brake lines are allowed.
- i. Front and rear brake pads may be changed. Brake pad locking pins may be modified for quick change type.
- j. Additional air scoops or ducts are not allowed.
- k. Motorcycles must be equipped with brake lever protection, intended to protect the handlebar brake lever from being accidentally activated in case of collision with another motorcycle. Composite guards are not permitted. FIM approved guards will be permitted without regard of the material. The Technical Director has the right to refuse any guard not satisfying this safety purpose

5.6.9.7 Handlebars and hand controls

- a. Handlebars may be replaced.
- b. Handlebars and hand controls may be relocated.
- c. Throttle controls must be self closing when not held by the hand.
- d. Throttle assembly and associated cables may be modified or replaced but the connection to the throttle body and to the throttle controls must remain as on the homologated motorcycle. Cable operated throttles (grip assembly) must be equipped with both an opening and a closing cable.
- e. Clutch and brake lever may be replaced with an after-market model. An adjuster to the brake lever is allowed.
- f. Motorcycles must be equipped with a functional ignition kill switch or button mounted on the left or right hand handlebar (within reach of the hand while on the hand grips) that is capable of stopping a running engine. The button or switch must be RED.

5.6.9.8 Foot rest / Foot controls

- a. Foot rests, hangers/brackets and hardware may be replaced and relocated but the hangers/brackets must be mounted to their original frame mounting points.
- b. Foot controls; gear shift and rear brake must remain operated manually by foot.
- c. Foot rests may be rigidly mounted or a folding type which must incorporate a device to return them to the normal position.

- d. The end of the foot rest must have at least an 8 mm solid spherical radius.
- e. Non folding footrests must have an end (plug) which is permanently fixed, made of aluminium, plastic, Teflon® or an equivalent type material (minimum radius 8mm). The plug surface must be designed to reach the widest possible area. The Technical Director has the right to refuse any plug not satisfying this safety aim.

5.6.9.9 Fuel tank

- a. Fuel tank must remain as originally produced by the manufacturer for the homologated motorcycle.
- b. All fuel tanks must be completely filled with fire retardant material (open-celled mesh, i.e. Explosafe®).
- c. Fuel tank breather pipes must be fitted with non-return valves that discharge into a catch tank with a minimum volume of 200cc made of a suitable material. The original catch tank can be changed.
- d. Fuel cap must remain as originally produced by the manufacturer for the homologated motorcycle. Fuel cap when closed must be leak proof.
- e. A rider spacer/pad may be fitted to the rear of the tank with nonpermanent adhesive. It may be constructed of foam padding or composite material.
- f. The sides of the fuel tank may be protected with a cover made of a composite material. These covers must fit the shape of the fuel tank.
- g. The fixing point of the fuel tank to the frame can be reinforced.
- h. Fuel tank cannot have heat reflective material attached to its bottom surface.

5.6.9.10 Fairing / Body work

- a. Fairing and bodywork may be replaced with exact cosmetic duplicates of the original parts, but must appear to be as originally produced by the manufacturer for the homologated motorcycle, with slight differences due to the different manufacturers (different pieces mix, fixing points, etc). The material may be changed. The use of carbon fiber or carbon composite materials is not allowed. Specific reinforcements in Kevlar® or carbon are allowed locally around holes and stressed areas.
- b. For all bodywork paint and decal design is free.
- c. Overall size and dimensions must be the same as the original part, with a tolerance of +/-10mm, respecting the design and features of the homologated fairing as far as possible. The overall width of the frontal area may be +10mm maximum. The decision of the Technical Director is final.
- d. Wind screen may be replaced with an aftermarket product. The height of the windscreen is free, within a tolerance of +/- 15 mm referred to the vertical distance from/to the upper fork bridge. The screen must conform to the same profile from the front as the original. From a top view the length of the windscreen may be shortened by 25mm to allow clearance for the rider. The edge of the screen must have no sharp edges.
- e. Fairing brackets may be altered or replaced.
- f. Air ducts that could feed the airbox cannot be added to the fairing. The only air duct allowed is the one present in the airbox.

- g. The lower fairing must be constructed to hold, in case of an engine breakdown minimum 2,5 litres. The lower edge of all the openings in the fairing must be positioned at least 70 mm above the bottom of the fairing.
- h. The upper edge of the rear transverse wall of the lower fairing must be at least 70 mm above the bottom. The angle between this wall and the floor must be $\leq 90^\circ$.
- i. Motorcycles may be equipped with a radiator shroud (inner ducts) to improve the air stream towards the radiator but the appearance of the front, the rear and the profile of the motorcycle must not be changed.
- j. The lower fairing may incorporate at least one (1) opening of $\varnothing 25$ mm diameter in the front lower area. This hole must remain sealed in dry conditions and must be only opened in wet race conditions.
- k. Front mudguards may be eliminated or replaced with a cosmetic duplicate of the original parts and may be spaced upward for increased tyre clearance.
- l. Rear mudguards are forbidden.

5.6.9.11 Seat

- a. Seat, seat base and associated bodywork may be replaced. The appearance from front, rear and profile must conform to the homologated shape. The length of the seat bodywork can be modified to allow taller riders.
- b. No part of the motorcycle may be behind a line drawn vertically at the edge of the rear tyre.
- c. The seat unit shall have a maximum height of the (approximately) vertical section behind the rider's seating position of 150 mm. The measurement will be taken at a 90° angle to the upper surface of the flat base at the rider's seating position, excluding any seat pad or covering.
- d. Same materials as fairings must be used (article 5.6.8.10.a).
- e. All exposed edges must be rounded.

5.6.9.12 Fasteners

- a. Standard fasteners may be replaced with fasteners of any material and design but titanium fasteners cannot be used. The strength and design must be equal to or exceed the strength of the standard fastener.
- b. Fasteners may be drilled for safety wire, but intentional weight-reduction modifications are not allowed.
- c. Thread repair using inserts of different material such as helicoils and timeserts is allowed.
- d. Aluminium fasteners may only be used in non-structural locations.

5.6.9.13 Rear Safety Light

All motorcycles must have a functioning red light mounted at the rear of the machine, to be used in rain or low visibility conditions. The team must ensure that the light is switched on any time the motorcycle is on the track or being ridden in the pit-line whenever a rain tyre is fitted on the motorcycle. All lights must comply with the following:

- a. Lighting direction must be parallel to the machine centre line (motorcycle running direction), and be clearly visible from the rear at least 15 degrees to both left and right sides of the machine centre line.
- b. The rear light must be mounted near the end of the seat/rear bodywork and approximately on the machine centre line, in a position approved by the Technical Director. In case of dispute over the mounting position or visibility, the decision of the Technical Director will be final.
- c. Power output/luminosity equivalent to approximately: 10 – 15 (incandescent), 0.6 – 5 W (LED).
- d. The output must be continuous - no flashing safety light whilst on track, flashing is allowed in the pit lane when pit limiter is active.
- e. Safety light power supply may be separated from the motorcycle.
- f. The Technical Director has the right to refuse any light system not satisfying this safety purpose.

5.6.10 The following items MAY be altered or replaced from those fitted to the homologated motorcycle.

- a. Any type of lubrication, brake or suspension fluid may be used.
- b. Gaskets and gasket materials.
- c. Painted external surface finishes and decals.
- d. Material for brackets connecting non original parts (fairing, instruments, etc) to the frame (or engine) cannot be made from titanium or fiber reinforced composites excepting the exhaust silencer that may be in carbon.

5.6.11 The following items MAY BE removed

- a. Bolt-on accessories on a rear sub frame.
- b. Front mudguard.

5.6.12 General Items

5.6.12.1 Materials

The use of titanium in the construction of the frame, the front forks, the handlebars, the swing-arms, the swing-arm spindles and the wheel spindles is forbidden. For wheel spindles, the use of light alloys is also forbidden. The use of titanium alloy nuts and bolts isn't allowed in this class.

- a. Titanium test to be performed on the track: magnetic test (titanium is not magnetic).
- b. The 3 % nitric acid test (titanium does not react. If metal is steel, the drop will leave a black spot).

- c. Specific weight of titanium alloys is between 4.5 and 5.0 kg/dm³ vs, over 7.48 kg/dm³ of steel and can be ascertained by weighing the part and measuring its volume in a calibrated glass filled with water (intake valve, rocker, connecting rod, etc.)
- d. In case of doubt, the test must take place at a Material Testing Laboratory.

5.6.12.2 Handlebars and Control Levers

Exposed handlebar ends must be plugged with a solid material or rubber covered.

The minimum angle of rotation of the steering on each side of the centre line or mid position must be of 15°.

Whatever the position of the handlebars, the front wheel, tyre and the mudguard must maintain a minimum gap of 10 mm.

Solid stops, (other than steering dampers) must be fitted to ensure a minimum clearance of 30 mm between the handlebar with levers and the tank, frame or other bodywork when on full lock to prevent trapping the rider's fingers.

Repair by welding of light alloy handlebars is prohibited.

Composite handlebars are not allowed.

All handlebar levers (clutch, brake, etc.) must be ball ended (diameter of this ball to be at least 16 mm). This ball can also be flattened, but in any case the edges must be rounded (minimum thickness of this flattened part 14 mm). These ends must be permanently fixed and form an integral part of the lever.

Each control lever (hand and foot levers) must be mounted on a independent pivot.

The brake lever, if pivoted on the footrest axis, must work under all circumstances, such as the footrest being bent or deformed.

Modified rider controls will be considered for the mobility challenged subject to a report by the Medical director, the Technical Directors decision is final.

Clutch lever may have a guard fitted equivalent to a brake lever guard.

5.6.12.3 Compulsory safety Items

- a. All drain plugs must be lock wired (safety wired). External oil filter(s), screws and bolts that enter an oil cavity must be safety wired (i.e. on crankcases). The oil filter may optionally have a secondary retention mechanism.
- b. Where breather or overflow pipes are fitted they must discharge via existing outlets. The original closed system must be retained: no direct atmospheric emission is permitted.

5.6.12.4 Tyres

Tyres may be replaced from those fitted to the homologated motorcycle.

Only tyres distributed by the Official supplier at the event are authorized.

The tread pattern (if present) must be made exclusively by the manufacturer when producing the tyre.

5.6.12.5 The use of tyre warmers is allowed

5.6.12.6 Use of tyres

The competitors shall only use tyres distributed by the Official Supplier during the event.

For each event, all tyres must be made of the same quality and shall be strictly identical.

During qualifying practices and race(s), rear tyres may be required to be marked with tyre stickers (see Art. 5.6.6).

The Technical director may, at this discretion, require the exchange of one (1) or more competitors' tyres for a tyre sample under his control. The tyres exchanged remain under his/her control and he/she can exchange them for the ones of another competitor.

5.6.12.7 Ballast

The use of ballast is allowed to stay over the minimum weight limit. The use of ballast must be declared to the Technical Director at the preliminary checks.

The ballast must be made of solid metallic piece/s, firmly and securely connected, either through an adapter or directly to the main frame or engine, with a minimum of two (2) steel bolts (min. 8 mm diameter, 8.8 grade or over). Other equivalent technical solutions must be submitted to the Technical Director for his/her approval.

Fuel in the fuel tank can be used as ballast. Nevertheless, the verified weight may never fall below the required minimum weight.

5.6.12.8 Homologated Parts

Homologated parts are the OEM parts supplied fitted to the machine during manufacture and as delivered. Unless stated otherwise these parts may not be remade, refinished, treated, coated or modified in any way.

5.6.13 Timekeeping instruments

Refer to Appendix 9.

5.6.14 Rider's Safety equipment

Refer to **Appendix 11** ~~and 12~~.

5.6.15 Procedure for Technical Control

Refer to **Appendix 12**.

General Appendix 8 Motorcycle frame

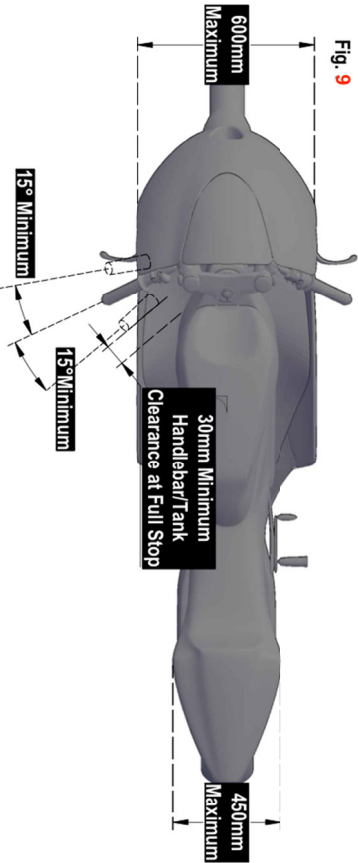
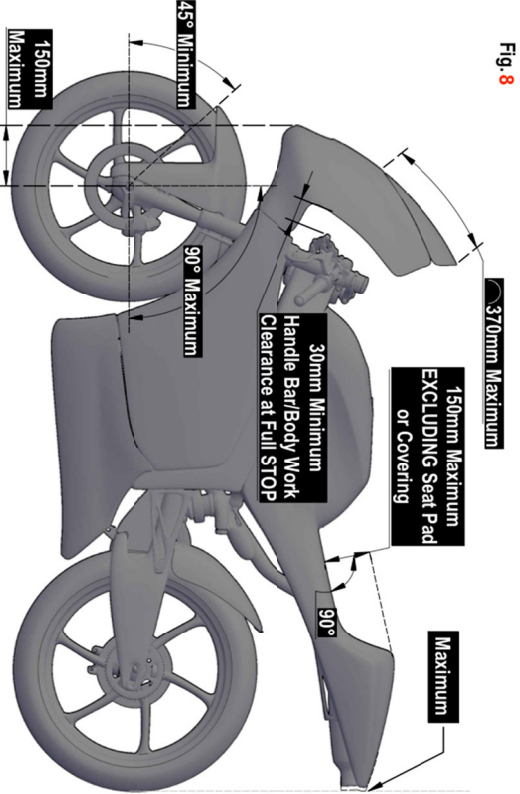
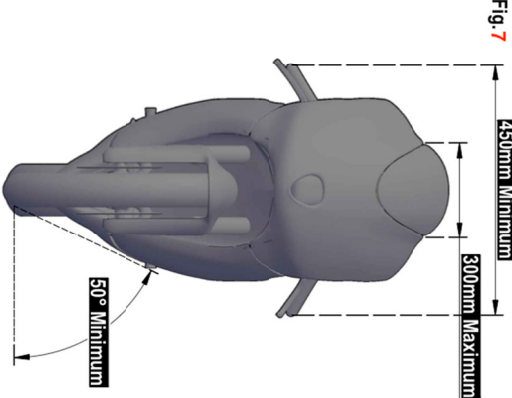

General Appendix 9 Transponder Installation

- a) All machines must have a correctly-positioned timekeeping transponder, of the correct type. The transponders will not be handed out by the time keeping staff of the circuits any longer. For this reason, the purchase or hiring of the transponders are the solely responsibility of the teams. The models allowed are:
- Tranx 2,
 - Tranx 260,
 - Tranx Pro DPI - DPT,
 - X2 Pro, X2 Pro plus and
 - X2 Club.
- b) The X2 transponder must be mounted on the front of the bike to optimize performance and cooling. Always use the supplied rubbers and top hats or mounting bracket to mount the transponder. The cable which connects to the transponder needs to be placed as close as possible to the transponder, on the same mounting area where the transponder is positioned. Avoid running any other cables and/or electronics in an area of 5cm around the transponder as this will affect the transponder signal. There has to be a Kevlar window in the fairing under the Transponder, as big as possible around the transponder area. The transponders cannot be mounted on or near the engine and/or the exhaust due to heat and vibrations. The transponder must always receive power supply; even in the case that the rider stops the bike.
- c) Transponders must be fully functional on the motorcycle as required by the Organiser, including wiring, power supply, and inputs / outputs for data or signals purposes.

Installation of the model X2 Pro and X2 Pro Plus



Installation of any other model

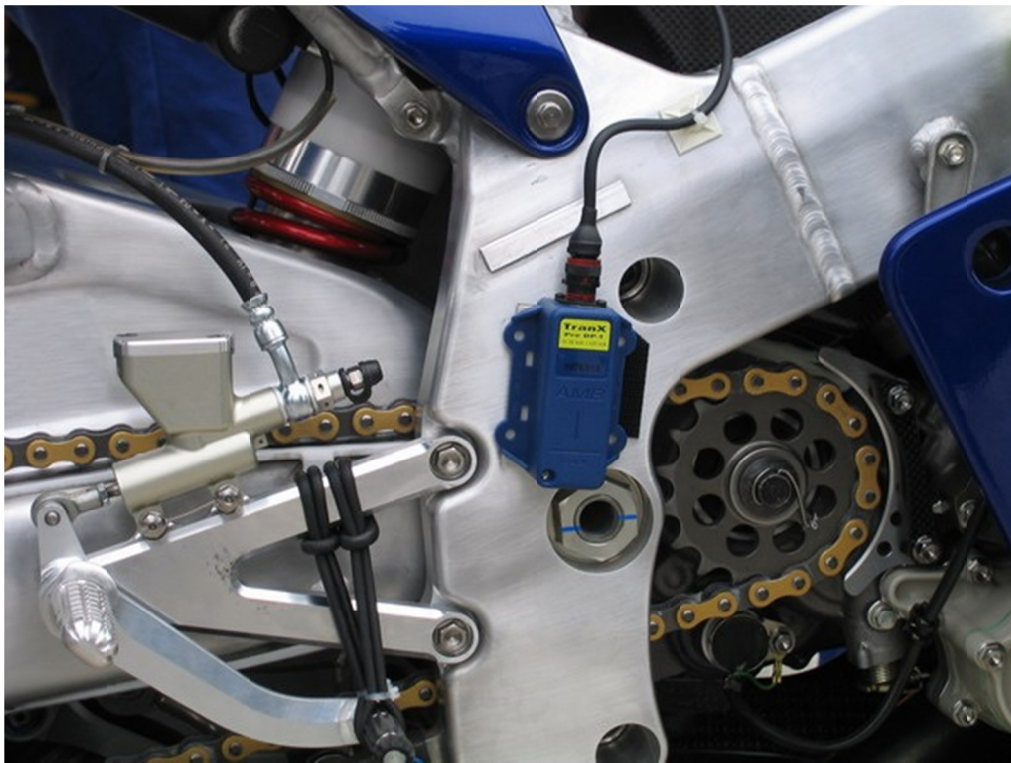

General Appendix 10 Fuel Specifications

1. All motorcycles must be fuelled with unleaded petrol, which must comply with the specification below for each racing class.
2. Unleaded petrol will comply with the specification below if:
 - a. It has the following characteristics:

| Property | Units | Min. | Max. | Test Method |
|------------------------|-------------------|------------------|---------|----------------------------|
| RON | | 95.0 | 102.0 | ISO 5164 |
| MON | | 85.0 | 90.0 | ISO 5163 |
| Oxygen | % (m/m) | | 2.7 | ISO 22854 |
| Benzene | % (v/v) | | 1.0 | ISO 22854 |
| Vapour Pressure (DVPE) | kPa | | 90 | EN 13016-1 |
| Lead | mg/L | | 5.0 | EN 237 |
| Density at 15°C | Kg/m ³ | 720.0 | 775.0 | ASTM D 4052 |
| Oxidation Stability | minutes | 360 | | ASTM D 525 |
| Existent gum | mg/100 mL | | 5.0 | EN ISO 6246 |
| Sulphur | mg/kg | | 10 | ASTM D 5453 |
| Nitrogen | % (m/m) | | 0.2 | ASTM D 4659 |
| Copper Corrosion | Rating | | Class 1 | ISO 2160 |
| Distillation: | | | | |
| At 70°C | % (v/v) | 22.0 | 50.0 | ISO 3405 |
| At 100°C | % (v/v) | 46.0 | 71.0 | ISO 3405 |
| At 150°C | % (v/v) | 75.0 | | ISO 3405 |
| Final Boiling Point | °C | | 210.0 | ISO 3405 |
| Residue | % (v/v) | | 2.0 | ISO 3405 |
| Olefins (*) | % (v/v) | | 18.0 | ISO 22854 |
| Aromatics (*) | % (v/v) | | 35.0 | ISO 22854 |
| Total di-olefins | % m/m | | 1.0 | GCMS / HPLC GCMS / HPLC |
| Apperance | | clear and bright | | Visual inspection |

All test methods include a precision statement. In cases of dispute, the procedures for resolving the dispute and interpretation of the results based on test method precision, described in ISO 4259, shall be used.

- b. The total of individual hydrocarbon components, containing only hydrogen and carbon, present at concentrations of less than 5% m/m must be at least 30% m/m of the fuel.

Compliance with the compositional regulation is calculated on the following basis:

$$A = 100 - B - C$$

where:

A is the total concentration (in % m/m) of individual hydrocarbon components present at concentrations less than 5 % m/m,

B is the total concentration (in % m/m) of oxygenates present in the fuel, and C is the total concentration (in % m/m) of individual hydrocarbon components present at concentrations greater than 5% m/m.

The test method will be gas chromatography.

- c. The total concentration of naphthenes, olefins and aromatics in each carbon number group will not exceed the limits given in the following table.

| % m/m | C4 | C5 | C6 | C7 | C8 | C9+ |
|------------|----|----|-----|----|----|-----|
| Naphthenes | 0 | 5 | 10 | 10 | 10 | 10 |
| Olefins | 5 | 20 | 20 | 15 | 10 | 10 |
| Aromatics | | | 1.2 | 35 | 35 | 30 |

Bicyclic and polycyclic olefins are not permitted. The fuel must contain no substances which are capable of exothermic reaction in the absence of external oxygen.

- d. Only the following oxygenates will be permitted:

Methanol, Ethanol, Iso-propyl alcohol, Iso-butyl alcohol, Methyl tertiary butyl ether, Ethyl tertiary butyl ether, Tertiary amyl methyl ether, Di-isopropyl ether, n-Propyl alcohol, Tertiary butyl alcohol, n-Butyl alcohol, Secondary butyl alcohol.

- e. Manganese (<1 mg/L), lead (<5 mg/L), iron (<5 mg/L) and nickel (<5 mg/L) additives are not permitted above these limits.
- f. In all classes, the fuel specification will be determined by the appointed fuel supplier in consultation with the Organisers and may be changed at any time by mutual agreement.

3. All classes fuel :

- a. Only fuel from the appointed fuel supplier is permitted. This fuel will be available at all official events, and will conform to this appendix specification. Use of this fuel without any addition or alteration is mandatory.

4. Fuel Sampling and Testing

- a. The Technical Director will appoint a senior Technical Scrutineer to take responsibility for the administration and supervision of the fuel sampling procedure.
- b. Motorcycles selected for fuel controls will usually be amongst the first three finishers, and will be directed to the "parc fermé" for technical controls.

- c. Other finishers may be chosen at random for fuel controls. A Technical Scrutineer will be posted at the entrance to the pit box of the selected rider(s) whose machine must immediately accompany the Technical Scrutineer to the technical control area or “parc fermé”.
- d. The fuel to be tested will be transferred into two bottles, “A” and “B” identified by reference to the rider, team and machine from which the sample was taken. The bottles will be closed, sealed and labelled by the Technical Director and/or Technical Scrutineer.
- e. Only new bottles will be used for the samples and only new materials will be used to transfer the fuel.
- f. The Fuel Sample Declaration form will be filled out immediately, containing all necessary information, including the riders and machines identity, date and place of fuel sampling. A responsible team member will sign this declaration, after verifying that all the information is correct.
- g. Sample “A” will be sent to the official appointed laboratory, accompanied by a copy of the Fuel Sample Declaration form. The fuel sample will be compared with the approved fuel. If necessary the concentration of other elements, including lead, manganese, iron, nickel, nitrogen and oxygen may be measured at the request of the Technical Director to ensure that octane and power boosters have not been added.
If any observed deviations indicate that they are due to mixing with one other fuel, which has been approved by the FIM/Dorna for use by the team, the fuel sample will be deemed to comply, provided the fuel sample still falls within the specification as described in this appendix.
Costs for the analyses of sample “A” will be paid by FIM/Dorna.
- h. Sample “B” will be handed over to the FIM designated storage facility for safeguarding in case of protests and/or requirement of a counter analysis by the appointed laboratory. Costs for the analyses of sample “B” will be paid by the team concerned.
- i. Both samples will be transported by an authorised courier.
- j. The laboratory must deliver the results of the fuel sample analyses to the Technical Director, with a copy to the Race Direction, as soon as possible after receipt of the samples.
- k. In the case of non-conformity, the Technical Director must notify, as soon as practical after receipt of the results, the Race Direction, the FIM Administration and the rider/team representative concerned.
Within 48 hours of the receipt of the notification of the results of the laboratory test of sample “A”, the team must notify the Race Direction and the Technical Director if counter-expertise is required (or not required) for sample “B”.
The Race Direction will take a decision at the event immediately following the notification of the results of the final expertise. Any appeal against the decision of the Race Direction will be heard by the FIM

Stewards appointed for the event at which the Race Direction decision is taken.

If there is no more events following the notification of the results of the final expertise, the Race Direction will take a decision as soon as practical. Any appeal against the decision of the FIM Stewards will be heard by the CDI appointed by the FIM for this specific task.

- l. The director of fuel analysis at the official laboratory must confirm to the Technical Director that the identification and the seal status of the “B” sample is correct before any B sample analysis is carried out.
- m. Failure of the sample to comply to approved petrol and/or the addition of octane and power boosters, as described in this Appendix, will automatically result in the disqualification of the competitor from the entire meeting.
The result of the competitor’s fuel sample analysis (“A” or “B” sample) more favourable to the competitor will be taken into account.
- n. Other specific tests can be suggested by the appointed fuel supplier in order to check if the fuel used is the one provided by the Championship fuel supplier.
These tests will be conducted by the Technical Director or his/her staff.

5. Fuel Temperature

In all classes, the fuel on the motorcycle must not be below the prevailing ambient temperature. Other than a simple removable fuel tank cover, the use of any device on the motorcycle to artificially decrease the fuel temperature below ambient temperature is forbidden.

6. Fuel Handling Safety

- a. The use of anti-static mats and grounding wrist straps is mandatory when filling fuel containers used for transferring fuel to **and from** motorcycles.
- b. The use of approved fuel fillers/fuel dumps is mandatory when adding **or removing** fuel to/**from** motorcycle fuel tanks.

Gasoline Sample Declaration Form



FIM WORLD CHAMPIONSHIPS, CUPS AND PRIZE EVENTS

Gasoline Sample Declaration Form

| | |
|--|--|
| Discipline | |
| IMN(xxx/xx) | |
| Rider/team's name | |
| Rider/team's number | |
| Rider/team's email or telephone number | |
| Team | |
| Vehicle's make | |
| Gasoline's make and type | |
| Gasoline's origin (public station or race supplier) | |
| Gasoline samples taken on date (dd/mm/yy) and time (hh:mm) | |

Gasoline samples taken at (right before or after) on:

QP1 QP2 WARM UP RACE N. _____

| | Container seal n° |
|----------|-------------------|
| Sample A | |
| Sample B | |

The above listed details refer to gasoline samples taken from the gasoline tank of the motorcycle specified.

Sample A is the first testing sample to be used by the FIM appointed laboratory. Sample B can be used for a second analysis if required by the FIM.

The serial numbers of the vial seals and the accuracy of the listed information have been verified.

Rider or Team responsible's name

Rider or Team responsible's signature

FIM Technical Director/FMNR Chief Technical
steward's name

FIM Technical Director/FMNR Chief Technical
Steward's signature

General Appendix 11 Riders' equipment & FIM Helmets standards

1. It is compulsory that each contracted rider must begin each race event with at least one complete set of undamaged safety equipment. A complete set of safety equipment shall contain:
 - Helmet
 - Leather Suit, 1-piece
 - Gloves
 - Boots
 - Back Protector
 - Chest Protector

The equipment must be worn, correctly fastened, at all times during on-track activity.

2. Safety Equipment Control

a) At Technical Control, one complete set of undamaged safety equipment must be presented and checked for the following:

- Helmet: a marking indicating certification **to the** helmet standard (**see below**).
- Leather Suit with additional leather padding or other protection on the principal contact points, knees, elbows shoulders, hips that conform to EN1621-1:2012. Check also point c)
- Linings or undergarments must not be made of a synthetic material which might melt and cause damage to the rider's skin.
- Riders must also wear leather gloves and boots, which with leather suit provide complete coverage from the neck down
- Back protector: must comply with EN1621-2, CB ("central back") or FB ("full back") Level 1 or 2.
- Chest protector: must comply with prEN1621-3 or EN 14021.

b) At any time during the season, the Technical Director may request a piece of rider's equipment in order to check that it meets the requirements listed.

c) The use of sliders (specific parts of the riders safety equipment, either permanently fixed or removable, intended to make regular contact with the track surface to assist the rider while cornering), is permitted on the knees, elbows or any other parts of the race suit, where it is deemed necessary. They must not be manufactured from or contain any material that when in contact with the track surface may cause visual or other disturbance to other riders.

3. FIM Rider's Equipment Minimum Requirements (REMR)

a) Standards for Helmet and Visor:

- Helmets must be of the full face type and conform to at least one of the following recognised International Standards, and be labeled:

Mandatory in Moto3 Junior. From 2021 also mandatory in Moto2 European Championship and European Talent Cup:

Helmets must comply with the FIM helmet standard. A list of FIM Homologated helmets is available on www.frhp.org.
See example of label below:

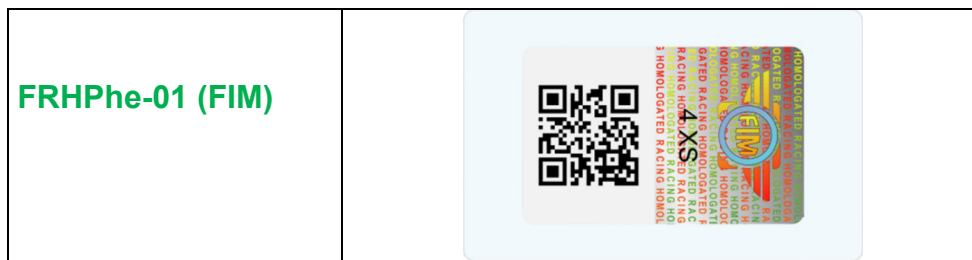

- Visors must be made of a shatterproof material.
- Disposable visor 'tear-offs' are permitted.
- A protective lower face cover must be present and must be not detachable, not moveable and made of the same material of the shell.
- Helmets constructed with an outer shell made of more than one piece are not permitted (e.g. they must not contain any seam).
- A retention system with a strap and the double D ring closing system is recommended.

4. Post-crash Riders Safety Equipment Check

After a crash the Technical Director may at his discretion request that the rider's safety equipment is checked prior to the start of the following practice session, warm up or race.

In the event that any item of equipment is considered, by either the Technical Director or the representative of the manufacturer of the item, to be too damaged for use on track, the rider will be required to replace or repair the item before being permitted on track.

Any question concerning the condition and suitability for use of the riders safety equipment shall be decided by the Technical Director, who may consult with the manufacturers of the product before making a final decision.

General Appendix 12 Procedures for Technical Control

The rider is at all times responsible for his/her motorcycle.

The Chief Technical Steward must be in attendance for an event at least 1 hour before the technical verifications are due to beginning. He must inform the Clerk of the Course, the Race Director and the Technical Director of his arrival.

He must ensure that all Technical Stewards, appointed for the event, carry out their duties in a proper manner.

He shall appoint the Technical Stewards to individual posts for the race, practices and final control.

The rider, or his mechanic, must be present with the motorcycle for Technical control within the time limits stated in the Time Schedule. The maximum number of persons present at the technical verification will be the rider, plus two others. In addition, the Team Manager will also be allowed.

The Technical Director/Chief Technical Steward must inform the Race Director of the results of the Technical control. The Technical Director/Chief Technical Steward will then draw up a list of accepted motorcycles and submit this list to the Clerk of the Course.

The Technical Director/Chief Technical Steward have the right to inspect any part of the motorcycle at any time of the event.

Any rider failing to report as required below may be disqualified from the event. Race Direction may forbid any team who does not comply with the rules, or any rider who may be a danger to other participants or to spectators, to take part in the practice sessions or in the races.

The Technical Control must be carried out in accordance with the procedure and times fixed in the General Information of the event.

The Technical Director/Chief Technical Steward will refuse any motorcycle that does not have a correctly-positioned positive transponder attachment. The transponder must be fixed to the motorcycle as described in Appendix 9.

The rider or the mechanic shall present a clean motorcycle and in conformity to the FIM rules. He shall also present the helmet, gloves, boots and leather.

An overall inspection of the motorcycle must be carried out in conformity with the FIM rules. Accepted motorcycles will be marked with paint or a sticker.

Technical Director/Chief Technical Steward has the final authority in case of a dispute on the conformity of the parts in question and for acceptance thereof.

Before each practice the Chief Technical Steward can confirm that the motorcycle has passed the Technical Control by checking the Technical Control sticker before the motorcycles go on the track.

Only accepted motorcycles may be used in practices and races.

Approximately 30 minutes after the Technical control have been completed, the Technical Director/Chief Technical Steward must submit to the Race Direction a list of accepted motorcycles and riders.

If a motorcycle is involved in an accident, the Technical Director/Chief Technical Steward may check the motorcycle, together with the helmet and clothing of the rider involved, to ensure that no defect of a serious nature has occurred. If a motorcycle was stopped with a Black Flag with Orange Disc, the Technical Director/Chief Technical Steward must check the motorcycle. In both cases, it is the responsibility of the team to present the motorcycle (together with helmet and clothing of the fallen rider) for his re-examination in case they wish to continue. If the helmet is clearly defective, the Chief Technical Steward must retain this helmet. The Promotor can send this helmet, together with the accident and medical report (and pictures and video, if available) to the Federation of the rider. If there are head injuries stated in the medical report, the helmet then must be sent to a neutral institute for examination.

The team can scrutineer only one motorcycle per rider.

If during the official practice sessions a motorcycle suffers any damages that are difficult to repair in the circuit, the Technical Director could allow a second motorcycle to be presented for a technical inspection. The process of authorizing a new machine to be used is not possible during a practice session. Once the starting procedure is initiated, it is not possible to verify a second motorcycle, neither in case of detention by red flag. In case of events with two races, once the first race is finished, the Technical Director may allow the request for verification of a second motorcycle.

Once the official practice sessions have started, only the motorcycle that has gone under the technical inspection will be allowed to be inside the box.

The Technical Director may require a team to provide such parts or sample as he may deem necessary.

In the case that a machine fails post-qualifying or post-race technical checks due to damage or technical issues on-track, the following protocol will apply, always at the sole discretion of the Technical Director.

- a) Machines under the minimum weight limit due to:
 - a. Loss of fluid:
 - i. If the Technical Director has verified that there is physical evidence of fluid loss due to an incident or mechanical issue on track, he may approve the fluid to be replenished to the levels as declared by the Manufacturer at the start of the season.
 - ii. If it is necessary to replace a damaged part to accommodate the fluid (eg. radiator), this will be permitted only under the supervision of the Technical Director who will confirm that the new part is identical to the damaged part.
 - b. Loss of material or parts:
 - i. If the Technical Director has verified that the machine has lost a part or material due to an incident or mechanical issue on track, he may approve the replacement of the part(s) with the following conditions:
 - ii. The Technical Director must verify that any new parts are identical to the original.

- iii. If the Technical Director determines that there is insufficient physical evidence to prove that a part or material is missing, then the original part must be found before it can be replaced.
- iv. Missing ballast weights will only be permitted to be replaced if they are found and returned to Technical Control by the circuit officials.

b) Machines exceeding the maximum noise levels:

- i. If the Technical Director is satisfied that there is sufficient physical evidence of damage or loss due to an incident or mechanical issue on track, he may approve the replacement of the missing or damaged exhaust parts, and the machine to be re-tested.

Noise tests

1. Noise tests must be conducted in an open area with a space of at least 10 metres between the motorcycle being tested and walls or other obstacles. There should be a minimum amount of ambient noise in the area.
2. The measuring equipment must be calibrated prior to the test and recalibrated at regular intervals.
3. The measuring equipment should be placed 50 cm from the end of the exhaust pipe and at 45 degree angle to the pipe either to the side or above.
4. The maximum noise level at all times is prescribed in the Technical Rules of each class..